

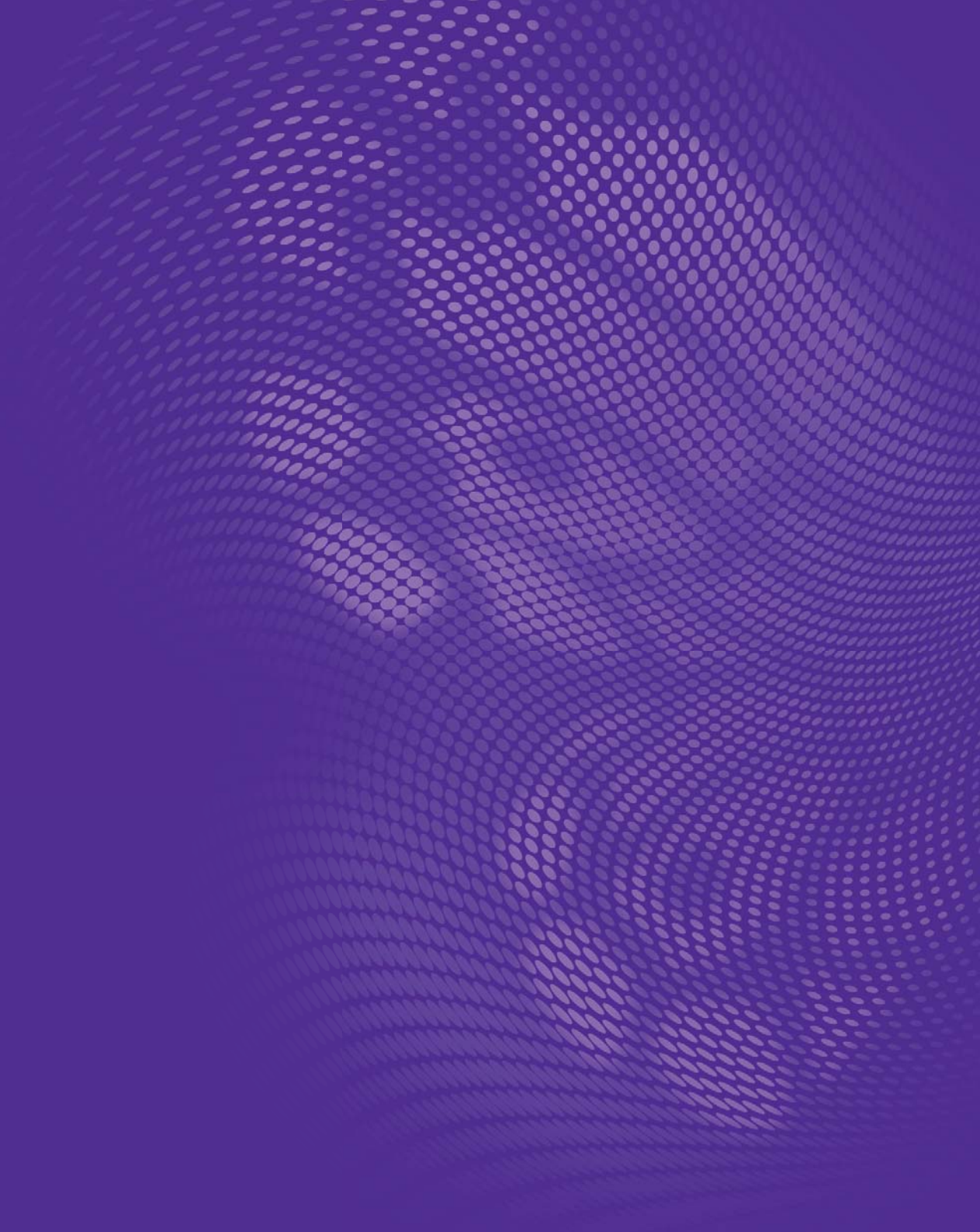

Corporate Identity and
Visual Identity Guidelines
June 2011





Index

A

Basic Design Elements

- A 01 The BenQ Logo
- A 02 Minimum Size, Minimum Staging Area
- A 03 Typography
- A 04 Corporate Colours

B

Basic Design System

- B 01 The BenQ Logo and Company Name
- B 02 Minimum Size, Minimum Staging Area
- B 03 The BenQ Logo and Contact Information
- B 04 The BenQ Logo and Tag Line

C

Applications

- C 01 Corporate VI Elements
- C 02 Stationery
- C 03 Business Forms
- C 04 Corporate Signage
- C 05 ID Materials
- C 06 Promotional Items
- C 07 Electronic Items



Index

A

Basic Design Elements

- A 01 The BenQ Logo
 - A 01.01 BenQ Logo and Logotype
 - A 01.02 BenQ Logo
 - A 01.03 BenQ 3D Logo Variations
 - A 01.04 BenQ 2D Logo Variations
 - A 01.05 BenQ Logotype
 - A 01.06 BenQ Logotype Variations
 - A 01.07 BenQ Bilingual Logo
 - A 01.08 BenQ Bilingual 3D Logo Variations Vertical
 - A 01.09 BenQ Bilingual 2D Logo Variations Vertical
 - A 01.10 BenQ Bilingual 3D Logo Variations Horizontal
 - A 01.11 BenQ Bilingual 2D Logo Variations Horizontal

- A 02 Minimum Size, Minimum Staging Area
 - A 02.01 BenQ 3D and 2D Logo Recommended Minimum Size and Minimum Staging Area
 - A 02.02 BenQ 3D Logo Staging Area for Banners and Signage
 - A 02.03 BenQ Logotype Recommended Minimum Size and Minimum Staging Area
 - A 02.04 BenQ Logotype Staging Area for Banners and Signage
 - A 02.05 BenQ Bilingual Logo Recommended Minimum Size and Minimum Staging Area
 - A 02.06 BenQ Logotype Registered and Trade Mark Symbol
 - A 02.07 BenQ Bilingual Logo Registered and Trade Mark Symbol
 - A 02.08 Incorrect Use

- A 03 Typography
 - A 03.01 Corporate Typeface, Alphabet
 - A 03.02 Corporate Typeface, Chinese

- A 04 Corporate Colours
 - A 04.01 Corporate Colours



Corporate Identity and Visual Identity Guidelines
Section A 01
The BenQ Logo



A 01.01 The BenQ Logo BenQ Logo and Logotype

BenQ Logo

The logo to be primarily used is the 3D BenQ Logo. This logo can print four colour process, or 2 colour PMS and is also available in Black and White. For instances when only one PMS colour can be used the 2D BenQ Logo should be used. This logo must never be altered in shape, i.e. it must never be traced, redrawn, distorted/stretched, cropped or made up of typesetting.



BenQ Logotype

The logotype can be used in BenQ Purple PMS 268 or can be reversed white from a dark background. It is also available in Black and White. The BenQ Logotype should be used in limited situations. These include:

1. Product Identity, when it is applied directly onto a product.
2. Where a large version of the logo is needed within a limited space, i.e. on side of product packaging, event banners, ID lanyards or signage.





A 01.02 The BenQ Logo BenQ Logo

3D BenQ Logo

The logo to be primarily used is the 3D BenQ Logo. It must never be altered in shape, i.e. it must never be traced, redrawn, distorted/stretched, cropped or made up of typesetting.

The Grid Scale

The grid scale is only used when precise means of reproduction are not available using professional reproduction equipment. This grid principle should be applied to all instances of the logo to ensure it is always replicated accurately.

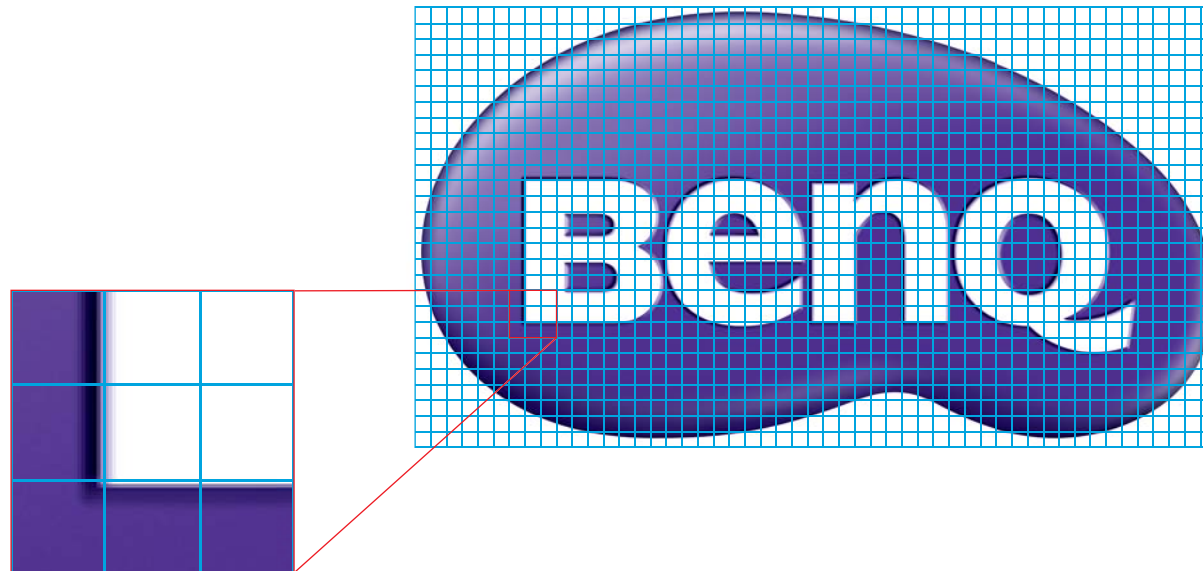

Inset 600%



A 01.03 The BenQ Logo BenQ 3D Logo Variations

BenQ 3D Logo

BenQ 3D Logo has been designed in colour for use on the following backgrounds.

BenQ 3D Logo is also supplied as Mono (Black and White)



Purple (P) White and/or Purple background

Black and White (BW) Black and/or White background

PMS

- BenQ_3D_P_PMS_Sm.psd
- BenQ_3D_P_PMS_Md.psd
- BenQ_3D_P_BGW_PMS_Sm.psd
- BenQ_3D_P_BGW_PMS_Md.psd
- BenQ_3D_P_BGW_PMS_Lg.psd
- BenQ_3D_P_BGP_PMS_Sm.psd
- BenQ_3D_P_BGP_PMS_Md.psd
- BenQ_3D_P_BGP_PMS_Lg.psd

- PMS logo background
- Purple: PMS 268
- CMYK Purple logo background
- Purple: C86 M100 Y0 K0
- RGB logo background
- Purple: R73 G37 B130

CMYK

- BenQ_3D_P_CMYK_Sm.psd
- BenQ_3D_P_CMYK_Md.psd
- BenQ_3D_P_BGW_CMYK_Sm.psd
- BenQ_3D_P_BGW_CMYK_Md.psd
- BenQ_3D_P_BGW_CMYK_Lg.psd
- BenQ_3D_P_BGP_CMYK_Sm.psd
- BenQ_3D_P_BGP_CMYK_Md.psd
- BenQ_3D_P_BGP_CMYK_Lg.psd

RGB

- BenQ_3D_P_RGB_Sm.psd
- BenQ_3D_P_RGB_Md.psd
- BenQ_3D_P_BGW_RGB_Sm.jpg
- BenQ_3D_P_BGW_RGB_Md.jpg
- BenQ_3D_P_BGW_RGB_Lg.jpg
- BenQ_3D_P_BGP_RGB_Sm.jpg
- BenQ_3D_P_BGP_RGB_Md.jpg
- BenQ_3D_P_BGP_RGB_Lg.jpg

BW

- BenQ_3D_BW_Sm.psd
- BenQ_3D_BW_Md.psd
- BenQ_3D_BGW_BW_Sm.psd
- BenQ_3D_BGW_BW_Md.psd
- BenQ_3D_BGW_BW_Lg.psd
- BenQ_3D_BGB_BW_Sm.psd
- BenQ_3D_BGB_BW_Md.psd
- BenQ_3D_BGB_BW_Lg.psd



A 01.04 The BenQ Logo BenQ 2D Logo Variations

BenQ 2D Logo

BenQ 2D Logo has been designed in colour for use on the following backgrounds.

BenQ 3D Logo is also supplied as Mono (Black and White)



Purple (P)

PMS
BenQ_2D_P_PMS.eps
CMYK
BenQ_2D_P_CMYK.eps
RGB
BenQ_2D_P_RGB.jpg

Black and White (BW)

PMS
BenQ_2D_BW_PMS.eps
CMYK
BenQ_2D_BW_CMYK.eps
RGB
BenQ_2D_BW_RGB.jpg



Purple Reversed (P)

PMS
BenQ_2D_P_PMS_Reveps
CMYK
BenQ_2D_P_CMYK_Reveps
RGB
BenQ_2D_P_RGB_Rev.jpg

Black and White Reversed (BW)

PMS
BenQ_2D_BW_PMS_Reveps
CMYK
BenQ_2D_BW_CMYK_Reveps
RGB
BenQ_2D_BW_RGB_Rev.jpg

PMS logo
Purple: PMS 268
CMYK logo
Purple: C86 M100 Y0 K0
RGB logo:
Purple: R73 G37 B130

CMYK logo
Black: C0 M0 Y0 K100
RGB logo:
Black: R0 G0 B0



A 01.05 The BenQ Logo BenQ Logotype

BenQ Logotype

The logotype can be used in BenQ Purple PMS 268 or can be reversed white from a dark background. It is also available in Black and White.

This is the only permitted format of the BenQ Logotype. It must never be altered in shape, i.e. it must never be traced, redrawn or made up of typesetting.

When to use the BenQ Logotype

1. Product Identity, when it is applied directly onto a product.
2. Where a large version of the logo is needed within a limited space, i.e. on side of product packaging, event banners ID lanyards or signage.

The Grid Scale

The grid scale is only used when precise means of reproduction are not available using professional reproduction equipment. This grid principle should be applied to all instances of the logo to ensure it is always replicated accurately.

BenQ

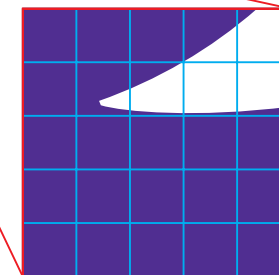
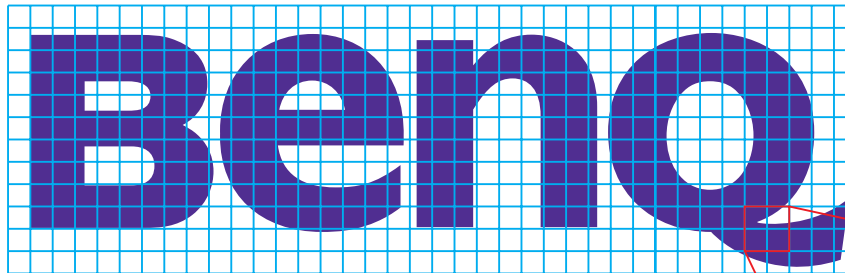

Inset 600%



A 01.06 The BenQ Logo BenQ Logotype Variations

BenQ Logotype

BenQ Logotype has been designed in colour for use on the following backgrounds.

Purple (P)

PMS
BenQ_Type_P_PMS.eps
CMYK
BenQ_Type_P_CMYK.eps
RGB
BenQ_Type_P_RGB.jpg

Black and White (BW)

CMYK
BenQ_Type_BW_CMYK.eps
RGB
BenQ_Type_BW_RGB.jpg



Purple Reversed (P)

PMS
BenQ_Type_P_PMS_Rev.eps
CMYK
BenQ_Type_P_CMYK_Rev.eps
RGB
BenQ_Type_P_RGB_Rev.jpg

PMS logo
Purple: PMS 268
CMYK logo
Purple: C86 M100 Y0 K0
RGB logo:
Purple: R73 G37 B130

Black and White Reversed (BW)

CMYK
BenQ_Type_BW_CMYK_Rev.eps
RGB
BenQ_Type_BW_RGB_Rev.jpg

CMYK logo
Black: C0 M0 Y0 K100
RGB logo:
Black: R0 G0 B0



A 01.07 The BenQ Logo BenQ Bilingual Logo

The lock-up between the BenQ Logo and the Chinese text has been carefully constructed and balanced. It has been designed in both vertical and horizontal formats. It must never be altered, i.e. it must never be traced, redrawn, distorted/stretched, cropped or made up of typesetting.

The Grid Scale

The grid scale is only used when precise means of reproduction are not available using professional reproduction equipment. This grid principle should be applied to all instances of the logo to ensure it is always replicated accurately.



明基

明基



明基



明基

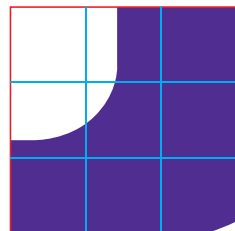

Inset 600%

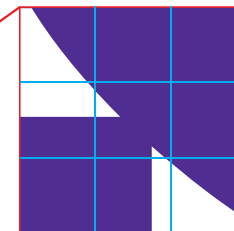
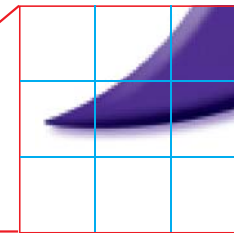
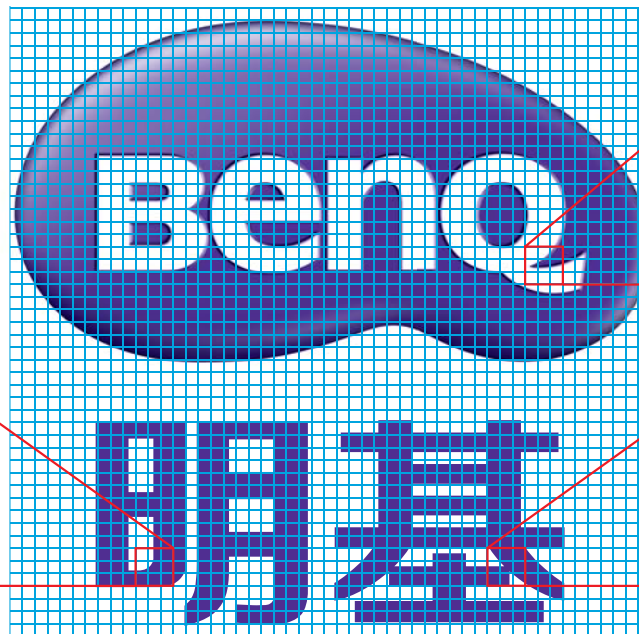



A 01.08 The BenQ Logo BenQ Bilingual 3D Logo Variations Vertical

BenQ Bilingual 3D Logo Vertical

BenQ Bilingual 3D Logo has been designed in colour for use on the following backgrounds.

BenQ Bilingual 3D Logo is also supplied as Mono (Black and White)



Purple (P) White and/or Purple background

CMYK
BenQ_Bi_3D_V_P_BGP_CMYK.psd
BenQ_Bi_3D_V_P_BGW_CMYK.psd

RGB
BenQ_Bi_3D_V_P_BGP_RGB.jpg
BenQ_Bi_3D_V_P_BGW_RGB.jpg

CMYK Purple logo background
Purple: C86 M100 Y0 K0
RGB logo background
Purple: R73 G37 B130

Black and White (BW) Black and/or White background

BW
BenQ_Bi_3D_V_BGB_BW.psd
BenQ_Bi_3D_V_BGW_BW.psd

BW logo background
Black: C0 M0 Y0 K100



A 01.09 The BenQ Logo

BenQ Bilingual 2D Logo Variations Vertical

BenQ Bilingual 2D Logo Vertical

BenQ Bilingual 2D Logo has been designed in colour for use on the following backgrounds.



Purple (P)

PMS
BenQ_Bi_2D_V_P_PMS.eps
CMYK
BenQ_Bi_2D_V_P_CMYK.eps
RGB
BenQ_Bi_2D_V_P_RGB.jpg

Black and White (BW)

CMYK
BenQ_Bi_2D_V_BW_CMYK.eps
RGB
BenQ_Bi_2D_V_BW_RGB.jpg



Purple Reversed (P)

PMS
BenQ_Bi_2D_V_P_PMS_Rev.eps
CMYK
BenQ_Bi_2D_V_P_CMYK_Rev.eps
RGB
BenQ_Bi_2D_V_P_RGB_Rev.jpg

Black and White Reversed (BW)

CMYK
BenQ_Bi_2D_V_BW_CMYK_Rev.eps
RGB
BenQ_Bi_2D_V_BW_RGB_Rev.jpg

PMS logo
Purple: PMS 268
CMYK logo
Purple: C86 M100 Y0 K0
RGB logo:
Purple: R73 G37 B130

CMYK logo
Black: C0 M0 Y0 K100
RGB logo:
Black: R0 G0 B0



A 01.10 The BenQ Logo BenQ Bilingual 3D Logo Variations Horizontal

BenQ Bilingual 3D Logo Horizontal

BenQ Bilingual 3D Logo has been designed in colour for use on the following backgrounds.

BenQ Bilingual 3D Logo is also supplied as Mono (Black and White)



Purple (P) White and/or Purple background

CMYK
BenQ_Bi_3D_H_P_BGP_CMYK.psd
BenQ_Bi_3D_H_P_BGW_CMYK.psd

RGB
BenQ_Bi_3D_H_P_BGP_RGB.jpg
BenQ_Bi_3D_H_P_BGW_RGB.jpg

CMYK Purple logo background
Purple: C86 M100 Y0 K0
RGB logo background
Purple: R73 G37 B130

Black and White (BW) Black and/or White background

BW
BenQ_Bi_3D_H_BGB_BW.psd
BenQ_Bi_3D_H_BGW_BW.psd

BW logo background
Black: C0 M0 Y0 K100



A 01.11 The BenQ Logo

BenQ Bilingual 2D Logo Variations Horizontal

BenQ Bilingual 2D Logo Horizontal

BenQ Bilingual 2D Logo has been designed in colour for use on the following backgrounds.



Purple (P)

PMS
BenQ_Bi_2D_H_P_PMS.eps
CMYK
BenQ_Bi_2D_H_P_CMYK.eps
RGB
BenQ_Bi_2D_H_P_RGB.jpg

Black and White (BW)

CMYK
BenQ_Bi_2D_H_BW_CMYK.eps
RGB
BenQ_Bi_2D_H_BW_RGB.jpg



Purple Reversed (P)

PMS
BenQ_Bi_2D_H_P_PMS_Rev.eps
CMYK
BenQ_Bi_2D_H_P_CMYK_Rev.eps
RGB
BenQ_Bi_2D_H_P_RGB_Rev.jpg

PMS logo
Purple: PMS 268
CMYK logo
Purple: C86 M100 Y0 K0
RGB logo:
Purple: R73 G37 B130

Black and White Reversed (BW)

CMYK
BenQ_Bi_2D_H_BW_CMYK_Rev.eps
RGB
BenQ_Bi_2D_H_BW_RGB_Rev.jpg

CMYK logo
Black: C0 M0 Y0 K100
RGB logo:
Black: R0 G0 B0



Corporate Identity and Visual Identity Guidelines
Section A 02
Minimum Size, Minimum Staging Area



A 02.01 Minimum Size, Minimum Staging Area BenQ 3D and 2D Logo Recommended Minimum Size and Minimum Staging Area

Recommended Minimum Size

The BenQ Logo may be reduced to a minimum width of 20mm for 3D Logo, and 10mm for 2D Logo.

Width 20mm



Width 10mm



Minimum Staging Area

The minimum staging area specification relates to the clear space around the logo which must be free from type and graphics. It is also an indication of the minimum distance from an edge that it can be placed on a product or print item. The minimum clear space for the BenQ Logo is the height of the letter 'B'.

To effectively communicate the BenQ brand, a minimum amount of space is to be left clear of symbols, logos, body text and icons. This does not apply when applying the BenQ Logo in isolation to the side of a package, banner or sign, or to sub-branding. Refer to the relevant sections for an explanation of the correct placement of the logo to an edge within a given space.





A 02.02 Minimum Size, Minimum Staging Area BenQ 3D Logo Staging Area for Banners and Signage

Minimum Staging Area

In this instance the minimum staging area is the minimum distance of the BenQ Logo away from the banner edge.

To effectively communicate the BenQ brand, the logo needs to be as large as possible within the given space. The BenQ Logo must be positioned as per the diagrams shown.

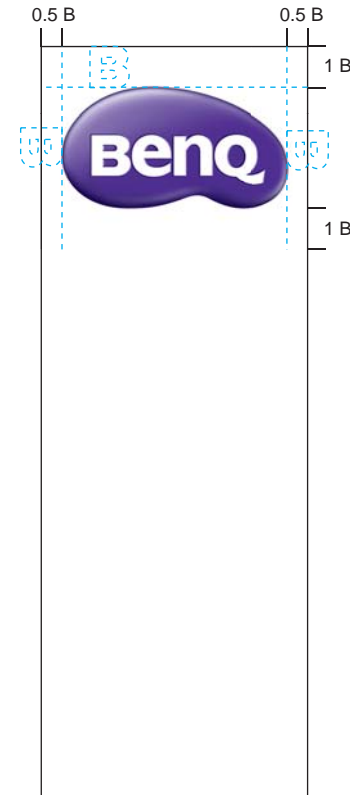



A 02.03 Minimum Size, Minimum Staging Area BenQ Logotype Recommended Minimum Size and Minimum Staging Area

Recommended Minimum Size

The BenQ Logotype may be reduced to a minimum width of 10mm.



Minimum Staging Area

The minimum staging area specification relates to the clear space around the logo which must be free from type and graphics. It is also an indication of the minimum distance from an edge that it can be placed on a product or print item. The minimum clear space for the logotype is 0.5 of the height of the letter 'B'.

To effectively communicate the BenQ brand a minimum amount of space is to be left clear of symbols, logos, body text and icons. This does not apply when applying the BenQ Logotype in isolation to the side of a package, banner or sign, or to sub-branding. Refer to the relevant sections for an explanation of the correct placement of the Logotype to an edge within a given space.





A 02.04 Minimum Size, Minimum Staging Area BenQ Logotype Staging Area for Banners and Signage

Minimum Staging Area

In this instance the minimum staging area is the minimum distance of the BenQ Logotype away from the banner edge.

To effectively communicate the BenQ brand, the logo needs to be as large as possible within the given space. The BenQ Logotype must be positioned as per the diagrams shown.

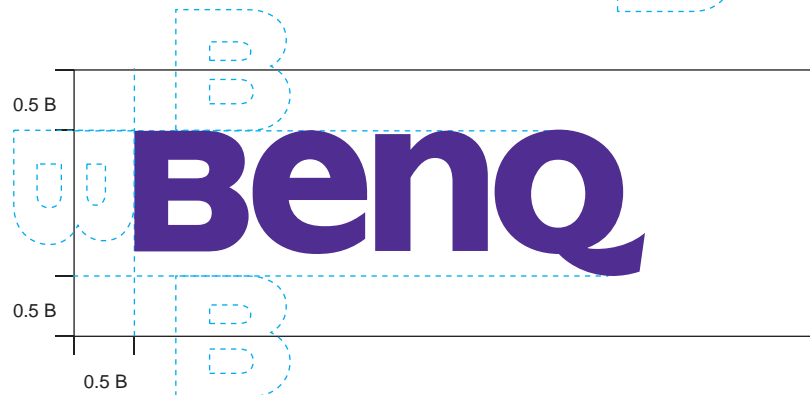
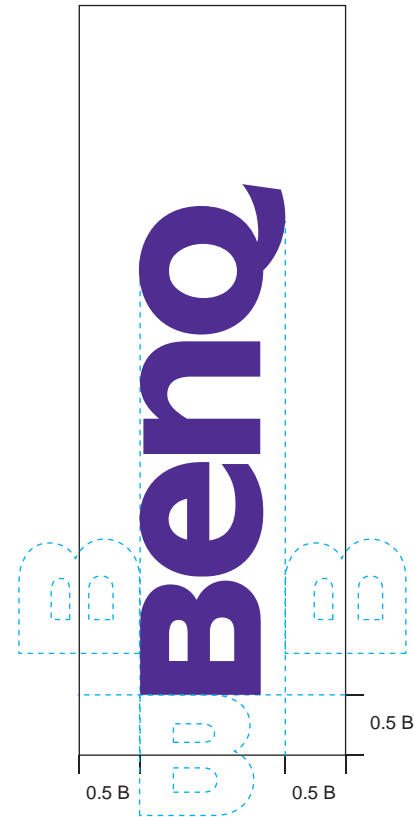



A 02.05 Minimum Size, Minimum Staging Area BenQ Bilingual Logo Recommended Minimum Size and Minimum Staging Area

Minimum Staging Area

The minimum staging area specification relates to the clear space around the logo which must be free from type and graphics. It is also an indication of the minimum distance from an edge that it can be placed on a product or print item. The minimum clear space for the Bilingual Logo is the height of the letter 'B'.

To effectively communicate the BenQ brand a minimum amount of space is to be left clear of symbols, logos, body text and icons. This does not apply when applying the BenQ Bilingual Logo in isolation to the side of a package, banner or sign, or to sub-branding. Refer to the relevant sections for an explanation of the correct placement of the Bilingual Logo to an edge within a given space.

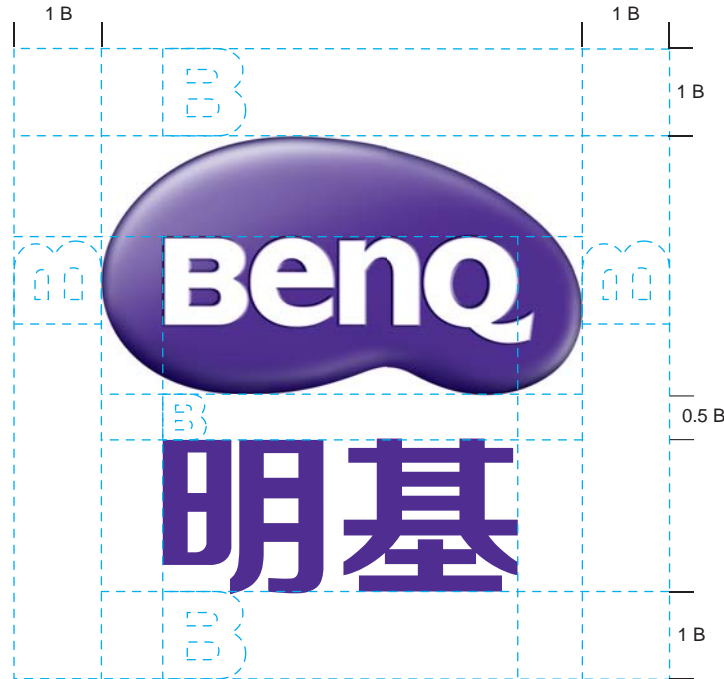

Width 20mm



Width 10mm





A 02.06 Minimum Size, Minimum Staging Area BenQ Logotype Registered and Trade Mark Symbol

™ / ® Placement for Logotype

Registered and Trade Mark symbols are placed at the top right of the BenQ Logotype.

The ® symbol is set in Arial Regular.
Do not redraw the symbol.
The ™ symbol is set in Arial Regular.
Do not redraw the symbol.

The size of the Registered and Trade Mark symbols is 0.15 of the height of the letter 'B'.
Please contact BenQ HQ Brand Management Center for master artworks of the BenQ Logotype with the ® or ™ symbol.

Standard





A 02.07 Minimum Size, Minimum Staging Area BenQ Bilingual Logo Registered and Trade Mark Symbol

™ / ® Placement for Text Logo

The size of the Registered and Trade Mark symbols is 0.15 of the height of the letter 'B'.

Chinese Version

The size of the Registered and Trade Mark symbols is 0.15 of the height of the letter 'B'.

In all cases, the ® and ™ symbol are set in Arial Regular.
Do not redraw the symbols.

Please contact BenQ HQ Brand Management Center for master artworks of the BenQ Bilingual Logo with the ® or ™ symbol.





A 02.08 Minimum Size, Minimum Staging Area Incorrect Use

Incorrect use of the 3D BenQ Shape Logo

Below are just a few examples of incorrect usage of the logo.



distorted



redrawn



cropped

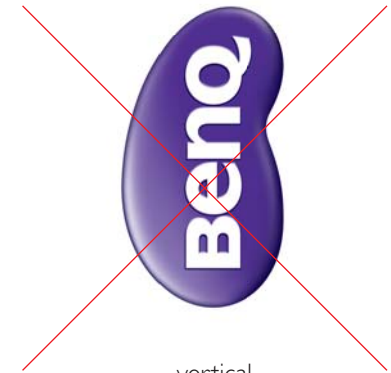

vertical



angled

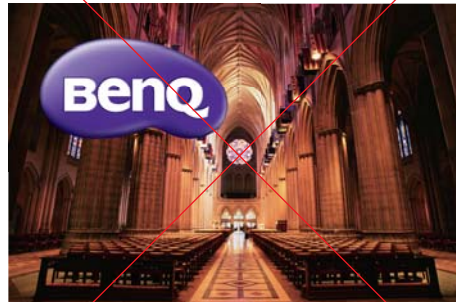

place directly over an image



too close to text



text adjusted within shape



Corporate Identity and Visual Identity Guidelines
Section A 03
Typography



A 03.01 Typography Corporate Typeface, Alphabet

Corporate Typeface Gill Sans MT

The corporate typeface should be used consistently throughout all corporate communication materials. Only the weights shown should be used.

Gill Sans MT is a sans serif typeface and is readily available from the Adobe collection. However, if you do not have access to these typefaces they can be purchased and downloaded from a number of font libraries. A selection of the websites for these libraries have been listed.

Usage Guide Gill Sans MT Light

To be used for body and lead copy.

abcdefghijklmnopqrstuvwxyz
ABCDEFGHIJKLMNPOQ
RSTUVWXYZ
(1234567890@&\$,.'";:+-%!?)

Gill Sans MT Regular

To be used for headings and sub headings.

abcdefghijklmnopqrstuvwxyz
ABCDEFGHIJKLMNPOQ
RSTUVWXYZ
(1234567890@&\$,.'";:+-%!?)

Secondary Typeface Arial Regular

The secondary typeface should be only used for technical copy such as specifications and captions for diagrams within manuals, product feature lists. Arial Regular is a sans serif typeface and is a system font.

Usage Guide Arial Regular

To be used for body copy, captions and specifications.

abcdefghijklmnopqrstuvwxyz
ABCDEFGHIJKLMNPOQ
RSTUVWXYZ
(1234567890@&\$,.'";:+-%!?)

Arial Bold

To be used for headings and sub headings.

abcdefghijklmnopqrstuvwxyz
ABCDEFGHIJKLMNPOQ
RSTUVWXYZ
(1234567890@&\$,.'";:+-%!?)

Alternative Typeface for Non-Alphabet

For languages which do not use the Roman alphabet (e.g, Arabic Script) or when Gill Sans MT is not available, fonts equivalent to the style of the Gill Sans MT typeface should be chosen. Any new fonts need approval from BenQ HQ Brand Management Center.

If no equivalent fonts for above languages are available, Arial Regular can be used.

Font Library Contact Details

www.fontshop.com
www.fontfactory.com
www.adobe.com

Note

Due to copyright law, BenQ is unable to provide these fonts. Therefore it is the responsibility of the agency or manufacturer to purchase the required fonts.



A 03.02 Typography Corporate Typeface, Chinese

Corporate Chinese Typeface for Traditional Chinese

Microsoft JhengHei should be used consistently throughout all corporate communication materials when traditional Chinese is required. Please contact BenQ HQ Brand Management Center to obtain the typeface.

Corporate Chinese Typeface for Simplified Chinese

Microsoft YaHei should be used consistently throughout all corporate communication materials when simplified Chinese is required. Please contact BenQ HQ Brand Management Center to obtain the typeface.

Traditional Chinese - Microsoft JhengHei

明基電通股份有限公司

台北市內湖區114基湖路16號

Simplified Chinese - Microsoft YaHei

明基电通有限公司

苏州市新区狮山路268号



Corporate Identity and Visual Identity Guidelines
Section A 04
Corporate Colours



A 04.01 Corporate Colours Corporate Colours

Colour and Application

The Corporate colour is BenQ Purple PMS 268.

This is the recommended colour for the BenQ Logo on corporate applications. Four colour process printing techniques vary from country to country. It is advised that Pantone® colour chips are always used to check colour proofs. Monitors display colour differently, regardless of model, manufacturer or platform. The specifications on the right ensure colour consistency. Do not use colour references or values from files where colour modes have been converted automatically.

Exceptions

When only one colour is available in applications such as press advertisements, the BenQ Logo may be reproduced as Black.

All colours indicated here are representative of the Pantone® Colour Matching System. They should be judged with the according Pantone® visual reference.

Any other direct output from this file, such as on-screen or colour print outs, will not give accurate values. Pantone® is a registered trademark of Pantone, Inc.

BenQ Corporate Colour

BenQ Purple: PMS 268

CMYK: C86 M100 Y0 K0

RGB: R73 G37 B130

Hexadecimal: R49 G25 B82

256 Web Colours only 33 00 66



Supplementary Corporate Colours

Black: PMS Process Black

CMYK: C0 M0 Y0 K100

RGB: R0 G0 B0





Index

B

Basic Design System

- B 01 The BenQ Logo and Company Name
 - B 01.01 BenQ English Lock-up Logos
 - B 01.02 BenQ English Lock-up Logo Construction
 - B 01.03 BenQ English 3D Lock-up Logo Variations
 - B 01.04 BenQ English 2D Lock-up Logo Variations
 - B 01.05 BenQ Chinese Lock-up Logos
 - B 01.06 BenQ Chinese Lock-up Logo Construction
 - B 01.07 BenQ Chinese 3D Lock-up Logo Variations
 - B 01.08 BenQ Chinese 2D Lock-up Logo Variations
 - B 01.09 BenQ Bilingual Lock-up Logos
 - B 01.10 BenQ Bilingual Lock-up Logo Construction
 - B 01.11 BenQ Bilingual 3D Lock-up Logo Variations
 - B 01.12 BenQ Bilingual 2D Lock-up Logo Variations

- B 02 Minimum Size, Minimum Staging Area
 - B 02.01 BenQ Logo Lock-up
 - B 02.02 Incorrect Use

- B 03 The BenQ Logo and Contact Information
 - B 03.01 Address Lock-up, Chinese and Alphabet
 - B 03.02 Address Lock-up, Alphabet Variations
 - B 03.03 Address Lock-up, Chinese Variations
 - B 03.04 BenQ Logo Web Address Lock-up

- B 04 The BenQ Logo and Tag Line
 - B 04.01 BenQ Logo Minimum Staging Area for Product Name
 - B 04.02 BenQ Logo and Tagline
 - B 04.03 BenQ Logo and Tagline Continued



Corporate Identity and Visual Identity Guidelines

Section B 01

The BenQ Logo and Company Name



B 01.01 The BenQ Logo and Company Name BenQ English Lock-up Logos

The BenQ English 3D Lock-up Logos

When the BenQ Log is used in conjunction with various company sector names, it is referred to as the 'Lock-up Logo'. It exists in 3D and 2D formats.

This logo must never be altered in shape, i.e. it must never be traced, redrawn, distorted/stretched or made up of typesetting.



BenQ_Grp_En_3D_P_CMYK.psd



BenQ_Sch_En_3D_P_CMYK.psd



BenQ_Gur_En_3D_P_CMYK.psd



BenQ_Cor_En_3D_P_CMYK.psd



BenQ_Hos_En_3D_P_CMYK.psd



BenQ_Med_En_3D_P_CMYK.psd



BenQ_Fdn_En_3D_P_CMYK.psd



BenQ_Mts_En_3D_P_CMYK.psd



B 01.02 The BenQ Logo and Company Name BenQ English Lock-up Logo Construction

The lock-up between the BenQ Logo the company sector names has been carefully constructed and balanced. It must never be altered, i.e. it must never be traced, distorted/stretched, replaced, moved or re-typed.



The Grid Scale

The grid scale is only used when precise means of reproduction are not available using professional reproduction equipment. this grid principle should be applied to all instances of the logo to ensure it is always replicated accurately.

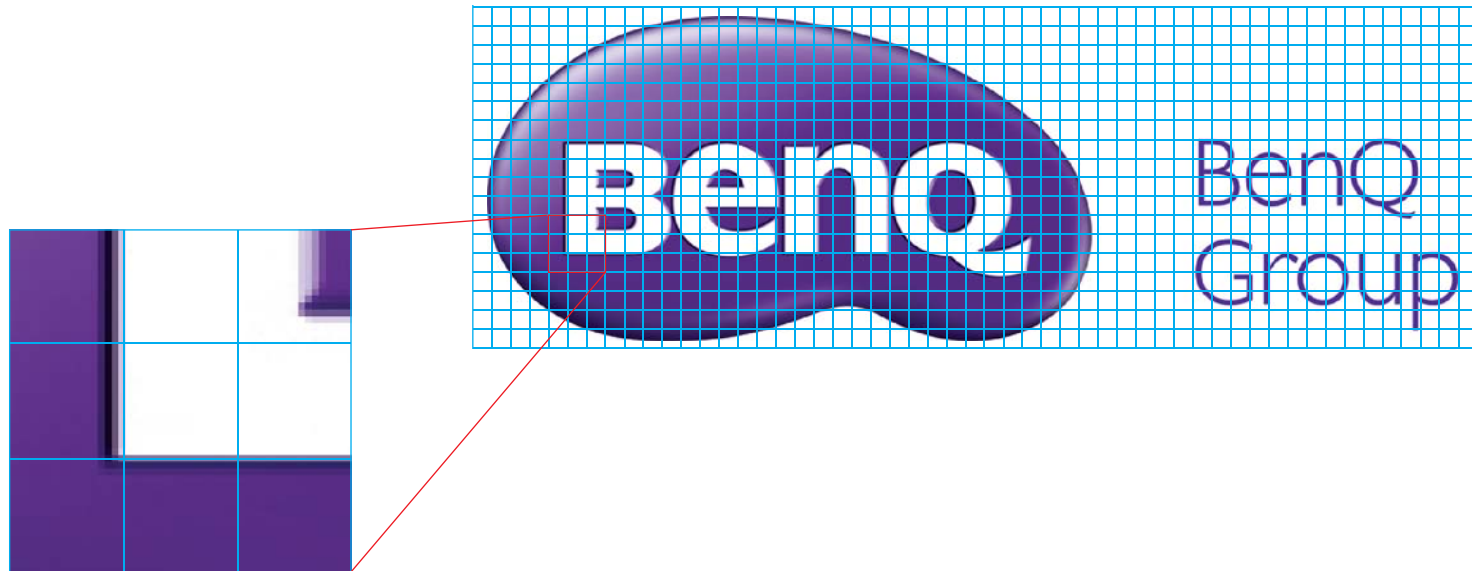

Inset 600%



B 01.03 The BenQ Logo and Company Name BenQ English 3D Lock-up Logo Variations

BenQ English 3D Lock-up Logo

BenQ English 3D Lock-up Logo has been designed in colour for use on the following backgrounds.

BenQ English 3D Lock-up Logo is also supplied as Mono (Black and White)



Purple (P) White and/or Purple background

CMYK
BenQ_Grp_En_3D_P_CMYK.psd

RGB
BenQ_Grp_En_3D_P_RGB.jpg

CMYK Purple logo background
Purple: C86 M100 Y0 K0
RGB logo background
Purple: R73 G37 B130

Black and White (BW) Black and/or White background

BW
BenQ_Grp_En_3D_BGB_BW.psd
BenQ_Grp_En_3D_BGW_BW.psd

BW logo background
Black: C0 M0 Y0 K100



B 01.04 The BenQ Logo and Company Name BenQ English 2D Lock-up Logo Variations

BenQ English 2D Lock-up Logo

BenQ English Lock-up Logos are additionally supplied as 2D variations.



Purple (P)

CMYK
BenQ_Grp_En_2D_P_CMYK.eps
RGB
BenQ_Grp_En_2D_P_RGB.jpg

Black and White (BW)

CMYK
BenQ_Grp_En_2D_BW_CMYK.eps
RGB
BenQ_Grp_En_2D_BW_RGB.jpg



Purple Reversed (P)

CMYK
BenQ_Grp_En_2D_P_CMYK_Rev.eps
RGB
BenQ_Grp_En_2D_P_RGB_Rev.jpg

CMYK logo
Purple: C86 M100 Y0 K0
RGB logo:
Purple: R73 G37 B130

Black and White Reversed (BW)

CMYK
BenQ_Grp_En_2D_BW_CMYK_Rev.eps
RGB
BenQ_Grp_En_2D_BW_RGB_Rev.jpg

CMYK logo
Black: C0 M0 Y0 K100
RGB logo:
Black: R0 G0 B0



B 01.05 The BenQ Logo and Company Name BenQ Chinese Lock-up Logos

The BenQ Chinese 3D Lock-up Logos

When the BenQ Logo is used in conjunction with various company sector names, it is referred to as the 'Lock-up Logo'. It exists in 3D and 2D formats.

This logo must never be altered in shape, i.e. it must never be traced, redrawn, distorted/stretched or made up of typesetting.



明基友達集團

BenQ_Grp_Ch_3D_P_CMYK.psd



明基學校

BenQ_Sch_Ch_3D_P_CMYK.psd



明基逐鹿

BenQ_Gur_Ch_3D_P_CMYK.psd



明基電通

BenQ_Cor_Ch_3D_P_CMYK.psd



明基醫院

BenQ_Hos_Ch_3D_P_CMYK.psd



明基三豐醫療器材

BenQ_Med_Ch_3D_P_CMYK.psd



明基友達基金會

BenQ_Fdn_Ch_3D_P_CMYK.psd



明基材料

BenQ_Mts_Ch_3D_P_CMYK.psd



B 01.06 The BenQ Logo and Company Name BenQ Chinese Lock-up Logo Construction

The lock-up between the BenQ Logo the company sector names has been carefully constructed and balanced. It must never be altered, i.e. it must never be traced, distorted/stretched, replaced, moved or re-typed.



The Grid Scale

The grid scale is only used when precise means of reproduction are not available using professional reproduction equipment. this grid principle should be applied to all instances of the logo to ensure it is always replicated accurately.

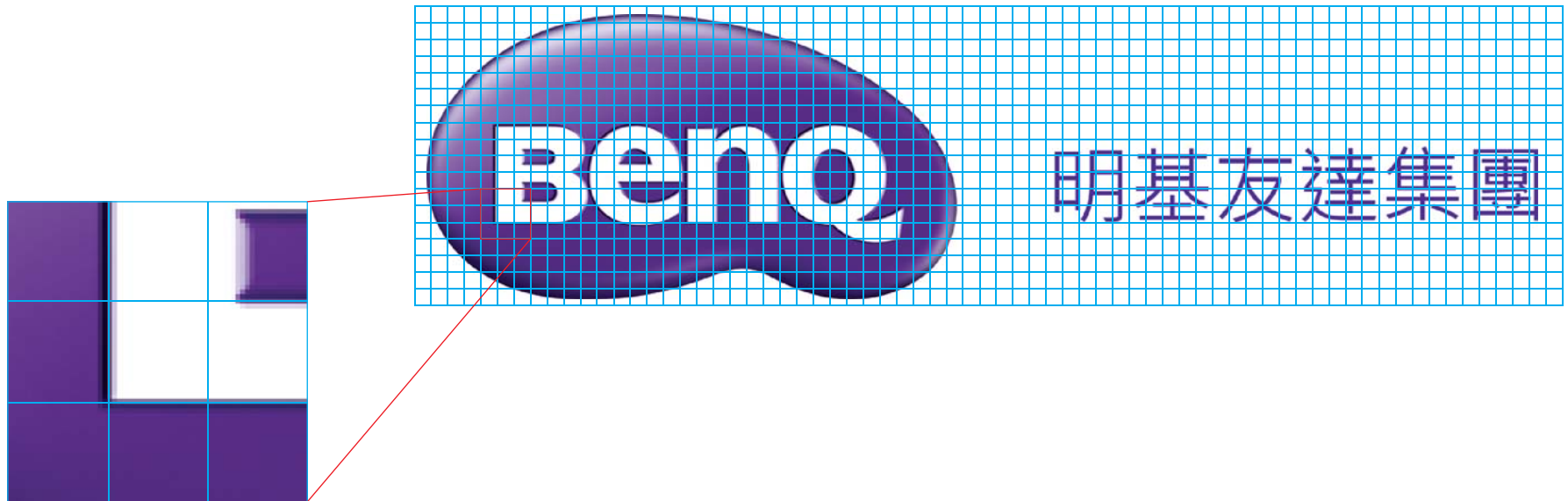

Inset 600%



B 01.07 The BenQ Logo and Company Name BenQ Chinese 3D Lock-up Logo Variations

BenQ Chinese 3D Lock-up Logo

BenQ Chinese 3D Lock-up Logo has been designed in colour for use on the following backgrounds.

BenQ Chinese 3D Lock-up Logo is also supplied as Mono (Black and White)



明基友達集團



明基友達集團



Purple (P) White and/or Purple background

CMYK
BenQ_Grp_Ch_3D_P_CMYK.psd

RGB
BenQ_Grp_Ch_3D_P_RGB.jpg

CMYK Purple logo background
Purple: C86 M100 Y0 K0
RGB logo background
Purple: R73 G37 B130



Black and White (BW) Black and/or White background

BW
BenQ_Grp_Ch_3D_BGB_BW.psd
BenQ_Grp_Ch_3D_BGW_BW.psd

BW logo background
Black: C0 M0 Y0 K100



B 01.08 The BenQ Logo and Company Name BenQ Chinese 2D Lock-up Logo Variations

BenQ Chinese 2D Lock-up Logo

BenQ Chinese Lock-up Logos are additionally supplied as 2D variations.



明基友達集團



明基友達集團

Purple (P)

CMYK
BenQ_Grp_Ch_2D_P_CMYK.eps
RGB
BenQ_Grp_Ch_2D_P_RGB.jpg

Black and White (BW)

CMYK
BenQ_Grp_Ch_2D_BW_CMYK.eps
RGB
BenQ_Grp_Ch_2D_BW_RGB.jpg



Purple Reversed (P)

CMYK
BenQ_Grp_Ch_2D_P_CMYK_Rev.eps
RGB
BenQ_Grp_Ch_2D_P_RGB_Rev.jpg

CMYK logo
Purple: C86 M100 Y0 K0
RGB logo:
Purple: R73 G37 B130

Black and White Reversed (BW)

CMYK
BenQ_Grp_Ch_2D_BW_CMYK_Rev.eps
RGB
BenQ_Grp_Ch_2D_BW_RGB_Rev.jpg

CMYK logo
Black: C0 M0 Y0 K100
RGB logo:
Black: R0 G0 B0



B 01.09 The BenQ Logo and Company Name BenQ Bilingual Lock-up Logos

The BenQ Bilingual 3D Lock-up Logos

When the BenQ Logo is used in conjunction with various company sector names, it is referred to as the 'Lock-up Logo'. It exists in 3D and 2D formats.

This logo must never be altered in shape, i.e. it must never be traced, redrawn, distorted/stretched or made up of typesetting.



明基友達集團
BenQ Group

BenQ_Grp_Bi_3D_P_CMYK.psd



明基學校
BenQ School

BenQ_Sch_Bi_3D_P_CMYK.psd



明基逐鹿
BenQ Guru

BenQ_Gur_Bi_3D_P_CMYK.psd



明基電通
BenQ Corporation

BenQ_Cor_Bi_3D_P_CMYK.psd



明基醫院
BenQ Hospital

BenQ_Hos_Bi_3D_P_CMYK.psd



明基三豐醫療器材
BenQ Medical Technology

BenQ_Med_Bi_3D_P_CMYK.psd



明基友達基金會
BenQ Foundation

BenQ_Fnd_Bi_3D_P_CMYK.psd



明基材料
BenQ Materials

BenQ_Mts_Bi_3D_P_CMYK.psd



B 01.10 The BenQ Logo and Company Name BenQ Bilingual Lock-up Logo Construction

The lock-up between the BenQ Logo the company sector names has been carefully constructed and balanced. It must never be altered, i.e. it must never be traced, distorted/stretched, replaced, moved or re-typed.



The Grid Scale

The grid scale is only used when precise means of reproduction are not available using professional reproduction equipment. this grid principle should be applied to all instances of the logo to ensure it is always replicated accurately.

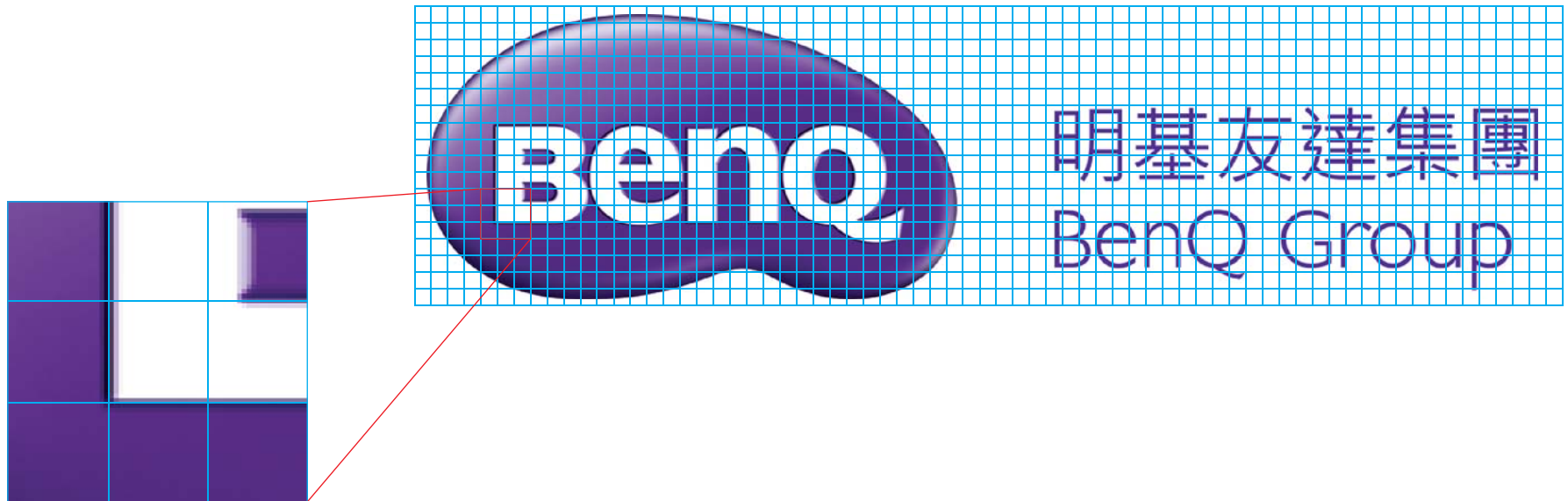

Inset 600%



B 01.11 The BenQ Logo and Company Name BenQ Bilingual 3D Lock-up Logo Variations

BenQ Bilingual 3D Lock-up Logo

BenQ Bilingual 3D Lock-up Logo has been designed in colour for use on the following backgrounds.

BenQ Bilingual 3D Lock-up Logo is also supplied as Mono (Black and White)



明基友達集團
BenQ Group



明基友達集團
BenQ Group



Purple (P) White and/or Purple background

CMYK
BenQ_Grp_Bi_3D_P_CMYK.psd

RGB
BenQ_Grp_Bi_3D_P_RGB.jpg

CMYK Purple logo background
Purple: C86 M100 Y0 K0
RGB logo background
Purple: R73 G37 B130



Black and White (BW) Black and/or White background

BW
BenQ_Grp_Bi_3D_BGB_BW.psd
BenQ_Grp_Bi_3D_BGW_BW.psd

BW logo background
Black: C0 M0 Y0 K100



B 01.12 The BenQ Logo and Company Name BenQ Bilingual 2D Lock-up Logo Variations

BenQ Bilingual 2D Lock-up Logo

BenQ Bilingual Lock-up Logos are additionally supplied as 2D variations.



明基友達集團
BenQ Group



明基友達集團
BenQ Group

Purple (P)

CMYK
BenQ_Grp_Bi_2D_P_CMYK.eps
RGB
BenQ_Grp_Bi_2D_P_RGB.jpg

Black and White (BW)

CMYK
BenQ_Grp_Bi_2D_BW_CMYK.eps
RGB
BenQ_Grp_Bi_2D_BW_RGB.jpg



Purple Reversed (P)

CMYK
BenQ_Grp_Bi_2D_P_CMYK_Rev.eps
RGB
BenQ_Grp_Bi_2D_P_RGB_Rev.jpg

CMYK logo
Purple: C86 M100 Y0 K0
RGB logo:
Purple: R73 G37 B130

Black and White Reversed (BW)

CMYK
BenQ_Grp_Bi_2D_BW_CMYK_Rev.eps
RGB
BenQ_Grp_Bi_2D_BW_RGB_Rev.jpg

CMYK logo
Black: C0 M0 Y0 K100
RGB logo:
Black: R0 G0 B0



Corporate Identity and Visual Identity Guidelines
Section B 02
Minimum Size, Minimum Staging Area



B 02.01 Minimum Size, Minimum Staging Area BenQ Logo Lock-up

Recommended Minimum Size

The BenQ Logo may be reduced to a minimum width of 20mm for 3D logo, and 10mm for 2D logo.



Minimum Staging Area

The minimum staging area for the Logo Lock-ups correlates to the staging area for all BenQ 3D and 2D Logos. The minimum clear space is equal to the height of the letter 'B'.

To effectively communicate the BenQ brand a minimum amount of space is to be left clear of symbols, logos, body text and icons. This does not apply when applying the BenQ Logo Lock-ups in isolation to the side of a package, banner or sign, or to sub-branding. Refer to the relevant sections for an explanation of the correct placement of the logo to an edge within a given space.

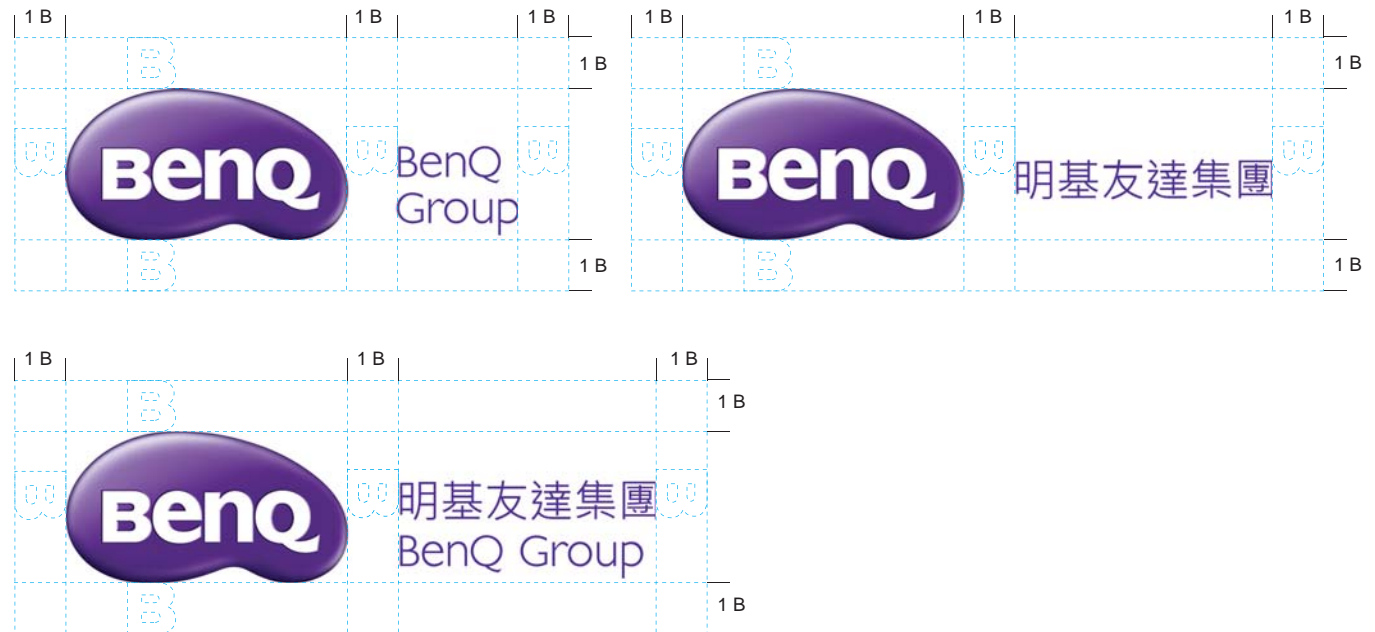



B 02.02 Minimum Size, Minimum Staging Area Incorrect Use

Incorrect use of the BenQ Logo Lock-up
Below are just a few examples of incorrect
usage of the Logo Lock-ups.



distorted



rearranged



cropped

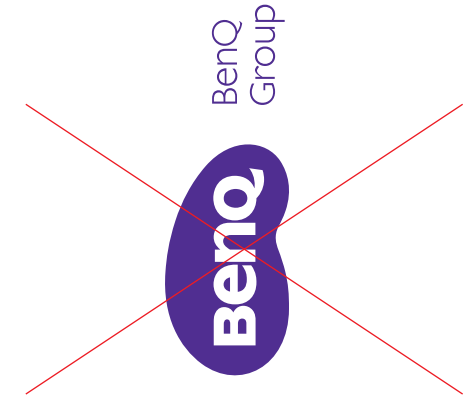

vertical



angled



change the colour of the logo



too close to text



retyped / adjusted text



Corporate Identity and Visual Identity Guidelines

Section B 03

The BenQ Logo and Contact Information



B 03.01 The BenQ Logo and Contact Information Address Lock-up, Chinese and Alphabet

When the BenQ Logo appears with corporate contact information, it is positioned as shown.

For Traditional Chinese, the company is set in Microsoft JhengHei. The address is set in Microsoft JhengHei. All numerals are set in Gill Sans MT.

The size may be adjusted to suit applications of varying sizes and functions.

Colour

Corporate Information should be BenQ Purple PMS 268 or reverse white from a dark background.

However for formal application, such as corporate stationery, text can also be Black or Cool Gray 11. Only 100% colour strength for both logo and text is permitted.



BenQ Corporation

16 Jihu Road, Neihu, Taipei 114, Taiwan

Tel +886-2-2658-8880 Ext.7231

Fax +886-2-6602-6677

Po.Su@BenQ.com

BenQ.com



明基電通股份有限公司

台北市114內湖區基湖路16號

電話 (02)2727-8899 分機7231

傳真 (02)6602-6677

Po.Su@BenQ.com

BenQ.com



B 03.02 The BenQ Logo and Contact Information Address Lock-up, Alphabet Variations

BenQ Corporation

16 Jihu Road, Neihu, Taipei 114, Taiwan
Tel +886-2-2658-8880 Ext.7231
Fax +886-2-6602-6677

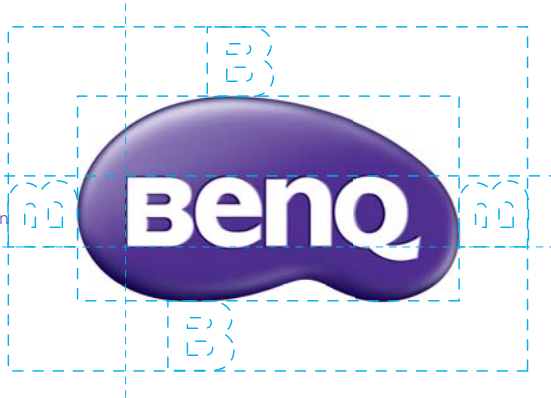

BenQ Corporation

16 Jihu Road, Neihu, Taipei 114, Taiwan
Tel +886-2-2658-8880 Ext.7231
Fax +886-2-6602-6677

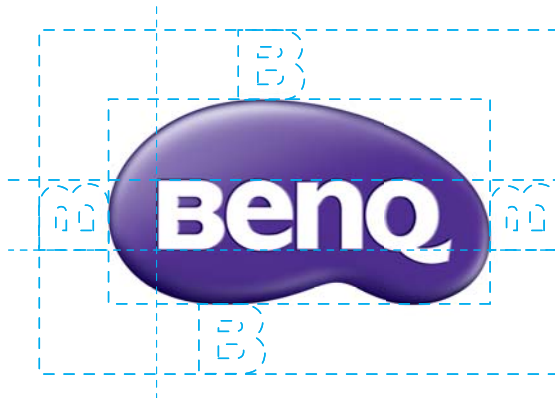
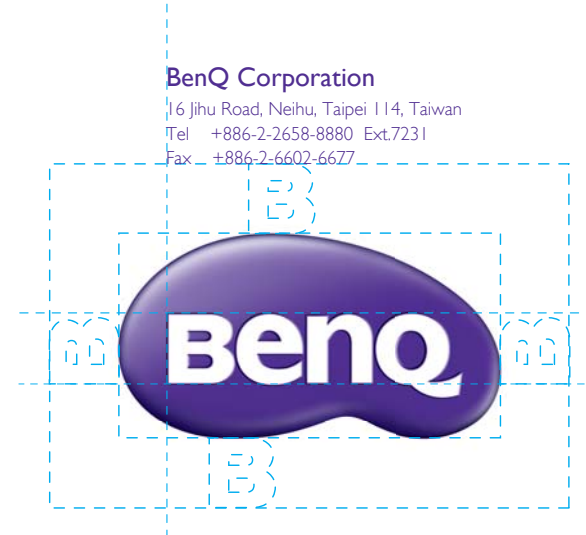

BenQ Corporation

16 Jihu Road, Neihu, Taipei 114, Taiwan
Tel +886-2-2658-8880 Ext.7231
Fax +886-2-6602-6677

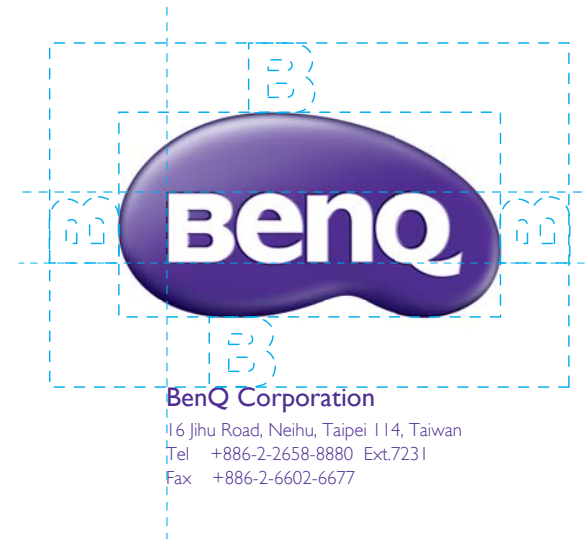

BenQ Corporation

16 Jihu Road, Neihu, Taipei 114, Taiwan
Tel +886-2-2658-8880 Ext.7231
Fax +886-2-6602-6677



B 03.03 The BenQ Logo and Contact Information Address Lock-up, Chinese Variations

明基電通股份有限公司

台北市114內湖區基湖路16號
電話 (02)2727-8899 分機7231
傳真 (02)6602-6677



明基電通股份有限公司

台北市114內湖區基湖路16號
電話 (02)2727-8899 分機7231
傳真 (02)6602-6677



明基電通股份有限公司

台北市114內湖區基湖路16號
電話 (02)2727-8899 分機7231
傳真 (02)6602-6677



明基電通股份有限公司

台北市114內湖區基湖路16號
電話 (02)2727-8899 分機7231
傳真 (02)6602-6677

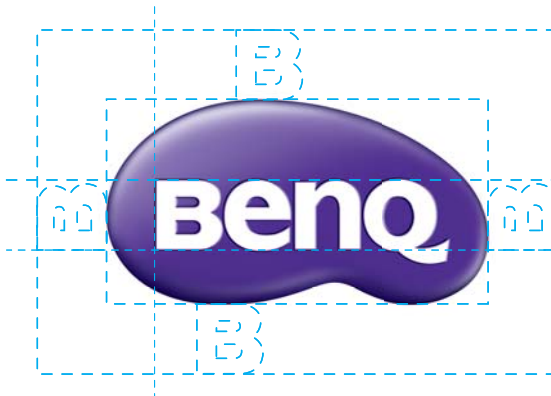



B 03.04 The BenQ Logo and Contact Information BenQ Logo Web Address Lock-up

When the BenQ Logo appears with the website address it can be placed in any position shown on this page.

The height of the website address should be 0.5 the height of 'B' in the BenQ Logo.

The website address is set in Gill Sans MT Light.

Colour

The website address should be BenQ Purple PMS 268 or reverse white from a dark background.

However for formal application, such as corporate stationery, text can also be Black or Cool Gray 11. Only 100% colour strength for both logo and text is permitted.

Small BenQ Logo and Text

When the BenQ Logo is small the website address should align with the 'B' within the logo and be no less than 15mm in width.

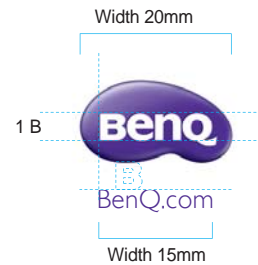
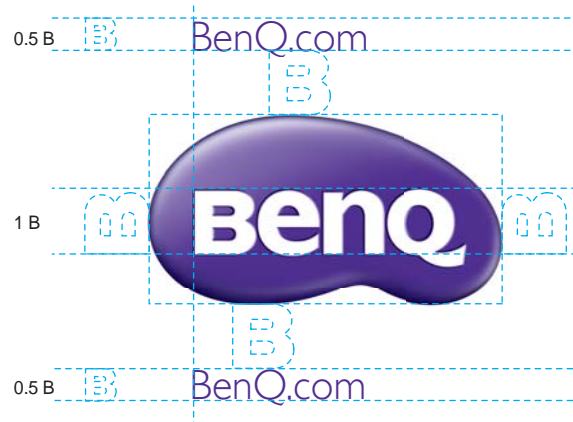

Optional Positions

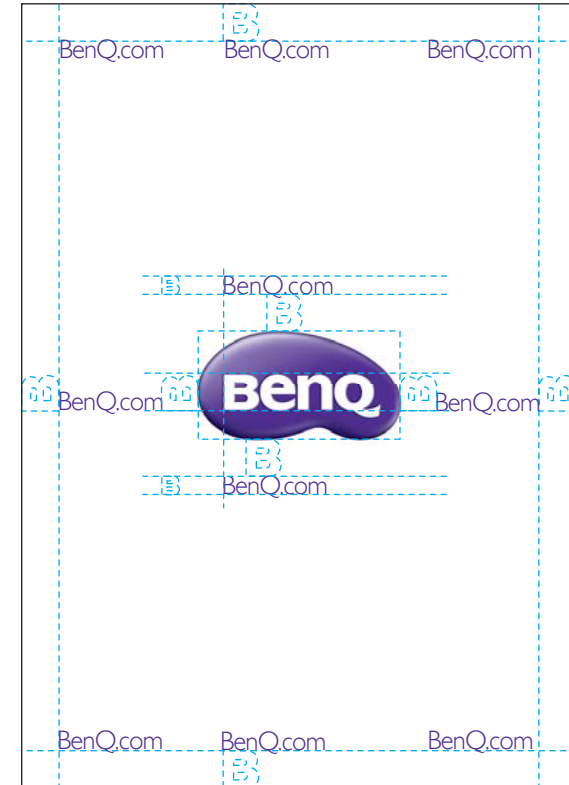



Corporate Identity and Visual Identity Guidelines

Section B 04

The BenQ Logo and Tag Line



B 04.01 The BenQ Logo and Tag Line BenQ Logo Minimum Staging Area for Product Name

The product name is set in Gill Sans MT Light.
The capital letter height of the product name is equal to the height of the 'B' in BenQ.

When locking up the product name and the BenQ Logo either of the following two formats must be used.

Horizontal Format

The product name is positioned beside the BenQ Logo a distance equal to the height of the letter 'B' from the logo. The product name must only be set in one line.

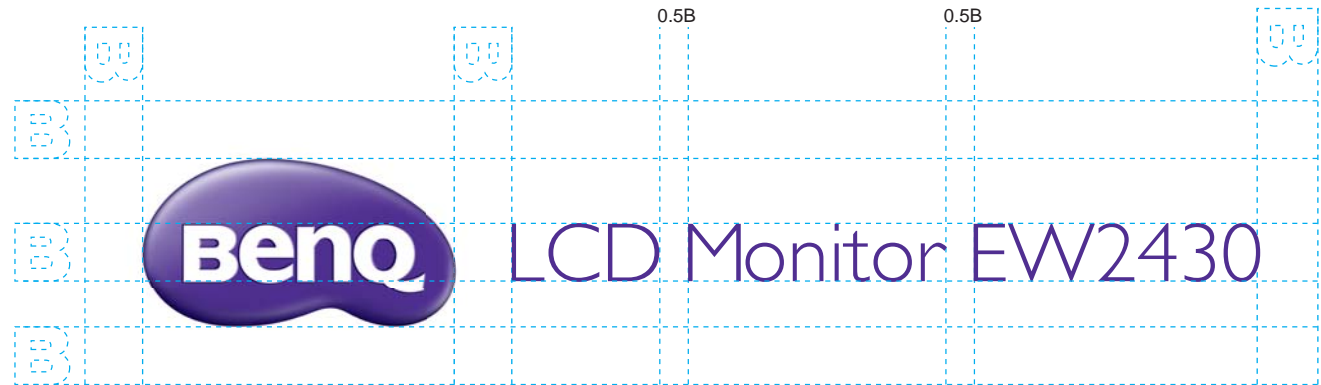

Horizontal Format

Vertical Format

The product name is positioned beneath the BenQ Logo a distance equal to the height of the letter 'B' from the logo. This format must be set in two lines. The product category goes in one line and the model name goes in another.

Colour

The BenQ Logo and the product name are BenQ Purple PMS 268 or may reverse white from a dark background.

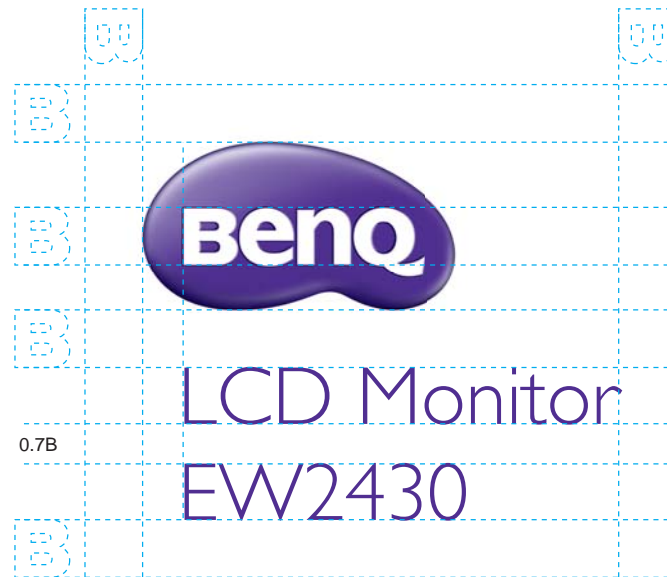

Vertical Format



B 04.02 The BenQ Logo and Tag Line BenQ Logo and Tagline

The lock-up between the BenQ Logo and the Tagline has been carefully constructed and balanced. It must never be altered, i.e. it must never be traced, redrawn, distorted/stretched, cropped or made up of typesetting.

The Tagline is set in Gill Sans Regular Italic. This is the only application where Gill Sans is used.

Colour

The BenQ Logo and the Tagline are BenQ Purple PMS 268 or may reverse white from a dark background.



Centre Aligned



Centre Aligned





B 04.03 The BenQ Logo and Tag Line BenQ Logo and Tagline Continued

BenQ Tagline 3D Lock-up Logo

BenQ Tagline 3D Lock-up Logo has been designed in colour for use on the following backgrounds.



Enjoyment Matters



享受快樂科技



Enjoyment Matters

Purple (P) White and/or Purple background

CMYK

BenQ_Tag_En_3D_P_BGP_CMYK.psd
BenQ_Tag_En_3D_P_BGW_CMYK.psd
BenQ_Tag_En_3D_BW_BGB_CMYK.psd
BenQ_Tag_En_3D_BW_BGW_CMYK.psd

RGB

BenQ_Tag_En_3D_P_BGP_RGB.jpg
BenQ_Tag_En_3D_P_BGW_RGB.jpg
BenQ_Tag_En_3D_BW_BGB_RGB.jpg
BenQ_Tag_En_3D_BW_BGW_RGB.jpg

CMYK Purple logo background

Purple: C86 M100 Y0 K0

RGB logo background

Purple: R73 G37 B130



享受快樂科技

Purple (P) White and/or Purple background

CMYK

BenQ_Tag_Ch_3D_P_BGP_CMYK.psd
BenQ_Tag_Ch_3D_P_BGW_CMYK.psd
BenQ_Tag_Ch_3D_BW_BGB_CMYK.psd
BenQ_Tag_Ch_3D_BW_BGW_CMYK.psd

RGB

BenQ_Tag_Ch_3D_P_BGP_RGB.jpg
BenQ_Tag_Ch_3D_P_BGW_RGB.jpg
BenQ_Tag_Ch_3D_BW_BGB_RGB.jpg
BenQ_Tag_Ch_3D_BW_BGW_RGB.jpg

CMYK Purple logo background

Purple: C86 M100 Y0 K0

RGB logo background

Purple: R73 G37 B130



C

Applications

- C 01 VI Elements
 - C 01.01 Corporate VI Colour Palette
 - C 01.02 Corporate VI Colour Palette - 2D Logo
 - C 01.03 Organic Shapes
 - C 01.04 Organic Wave Bar
 - C 01.05 Corporate VI Pattern One Wing
 - C 01.06 Corporate VI Pattern Two Wing
 - C 01.07 Corporate VI Pattern Two Wing Extended
 - C 01.08 Cropping Guide for the Corporate Pattern
 - C 01.09 Cropping Guide for the Corporate Pattern Continued
 - C 01.10 Vertical Cropping Guide for the Corporate Pattern
 - C 01.11 Horizontal Cropping Guide for the Corporate Pattern
 - C 01.12 Vertical Cropping Guide for the Corporate Pattern Reversed
 - C 01.13 Horizontal Cropping Guide for the Corporate Pattern Reversed
 - C 01.14 Corporate Pattern Incorrect Use
- C 02 Stationery
 - C 02.01 Business Cards
 - C 02.02 Letterhead
 - C 02.03 Letterhead A4
 - C 02.04 Letterhead US
 - C 02.05 Envelopes
 - C 02.06 Envelopes Environmentally Friendly
 - C 02.07 Envelopes Continued
 - C 02.08 Envelopes Continued
 - C 02.09 Presentation Folder
 - C 02.10 Presentation Folder Continued
 - C 02.11 Presentation Folder - Lever Arch or Ring Binder
 - C 02.12 Presentation Folder - Lever Arch or Ring Binder Continued
 - C 02.13 CD/DVD
 - C 02.14 CD/DVD Cover
- C 03 Business Forms
 - C 03.01 Internal Form
 - C 03.02 Alphabet Standard
 - C 03.03 Other Example
 - C 03.04 Other Example
 - C 03.05 Employee ID Card
 - C 03.06 Dealer Certificate
 - C 03.07 School Certificate
 - C 03.08 Award
 - C 03.09 Advertising Launch Poster - Corporate Pattern
 - C 03.10 Advertising Launch Poster - Corporate Pattern Reversed



Index

C

Applications

- C 04 BenQ Corporate Signage
 - C 04.01 Lobby Area Chinese
 - C 04.02 Lobby Area Alphabet
 - C 04.03 External Neon Sign
 - C 04.04 External Sign
 - C 04.05 External Sign
 - C 04.06 External Sign
 - C 04.07 Application Examples - Banners - Option 1
 - C 04.08 Application Examples - Banners - Option 2
 - C 04.09 Application Examples - Banners - Option 3
 - C 04.10 Application Examples - Corporate Flags
 - C 04.11 Application Examples - Company Flags
 - C 04.12 Vehicle Livery
 - C 04.13 Application Examples Repeat Logo for Media/Press Backdrop
 - C 04.14 Lectern
 - C 04.15 Lectern Continued
 - C 04.16 Lectern Specifications
- C 05 ID Materials
 - C 05.01 Generic Branding Badge
 - C 05.02 Multi-Purpose Employee Name Badge
- C 06 Promotional Items
 - C 06.01 Paper Cup
 - C 06.02 Plastic Bag
 - C 06.03 Plastic Bag - Reversed Pattern
 - C 06.04 Paper Bag
 - C 06.05 Paper Bag - Reversed Pattern
 - C 06.06 Paper Bag Environmentally Friendly
 - C 06.07 Uniforms, Polo Shirt
 - C 06.08 Cycling Jersey
 - C 06.09 Mug and Note Book
- C 07 Electronic Items
 - C 07.01 PowerPoint Template - Corporate
 - C 07.02 PowerPoint Template - Corporate Text Pages
 - C 07.03 Email Signature
 - C 07.04 Internal Form - Engineering
 - C 07.05 Internal Form - HR
 - C 07.06 Electronic Fax Template
 - C 07.07 Letterhead Template
 - C 07.08 Boilerplate Template
 - C 07.09 Factsheet
 - C 07.10 Company Profile



Corporate Identity and Visual Identity Guidelines
Section C 01
Corporate VI Elements



C 01.01 VI Elements Corporate VI Colour Palette

Colour and Application

The Corporate Colour is BenQ Purple PMS 268. The colour combinations specified on this page may be used for VI applications such as print, advertising, packaging and on products.

Four-colour process printing techniques vary from country to country. It is advised that Pantone® colour chips are always used to check colour proofs. Monitors display colour differently, regardless of model, manufacturer or platform. The specifications on the right ensure colour consistency. Do not use colour references or values from files where colour modes have been converted automatically.

Exceptions

When directly embossed onto products, the BenQ Logo may appear in the same colour as the material.

All colours indicated here are representative of the Pantone® Colour Matching System. They should be judged with the according Pantone® visual reference. Any other direct output from this file such as on-screen or colour print outs will not give accurate values. Pantone® is a registered trademark of Pantone, Inc.

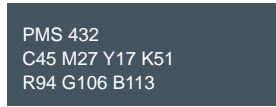
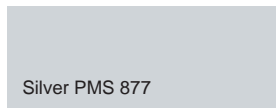
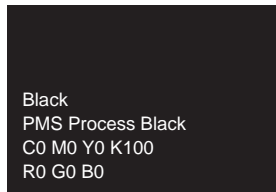
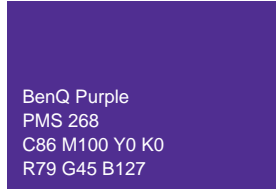

3D Logo



The BenQ logo may appear on a solid colour background or over a BenQ pattern.



Black and White 3D Logo



When Silver is not available the substitute color is Gray PMS 428.

Silver Substitute

Pantone Cool Gray 11 is only used as body text color on two color brochures.

Pantone PMS 432 is only used as body text color on stationery.

When printing four color process, it is necessary to specify that the PMS colors are matched exactly. Due to the variations of printing methods ink types and substrates used, the recommendation is to have the printer/reproduction company match the PMS colors from CMYK.



C 01.02 VI Elements

Corporate VI Colour Palette - 2D Logo

Note

The BenQ 3D Logo is the preferred logo, the 2D Logo should be used when only 1 colour printing is available.

BenQ Purple
PMS 268
C86 M100 Y0 K0
R79 G45 B127

2D Logo



The BenQ logo may appear on a solid colour background or over a BenQ pattern.



Black and White 2D Logo

Black
PMS Process Black
C0 M0 Y0 K100
R0 G0 B0



When Silver is not available the substitute color is Gray PMS 428.

Silver PMS 877

Silver Substitute

PMS 428
C12 M6 Y5 K12
R195 G200 B200

Pantone Cool Gray 11 is only used as body text color on two color brochures.

PMS Cool Gray 11
C48 M36 Y24 K66
R77 G79 B83

When printing four color process, it is necessary to specify that the PMS colors are matched exactly. Due to the variations of printing methods ink types and substrates used, the recommendation is to have the printer/reproduction company match the PMS colors from CMYK.

Pantone PMS 432 is only used as body text color on stationery.

PMS 432
C45 M27 Y17 K51
R94 G106 B113



C 01.03 VI Elements Organic Shapes

Master Shapes

A set of Organic Shapes have been established for use on print, advertising, point of sale, retail, exhibition and packaging items. These shapes may be used to mask specified patterns and photos or to house graphic elements as a die cut shape.

These shapes may only be used in conjunction with patterns specified in these guidelines and in accordance with application design specifications in these guidelines.

The BenQ Logo Organic Shape should only be used when it locks-up with the BenQ Logotype.

The shapes have been established for use on all applications. The artwork for these shapes is available in electronic vector format.

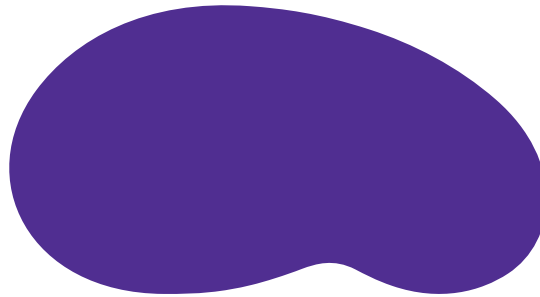

BenQ Logo Organic Shape
BenQ_LogoShape_CMYK.ai



BenQ Organic Shape 1
BenQ_OrgShape_1_CMYK.eps



BenQ Organic Shape 2
BenQ_OrgShape_2_CMYK.eps

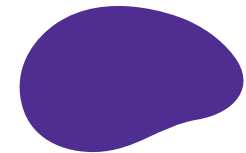

BenQ Organic Shape 3
BenQ_OrgShape_3_CMYK.eps

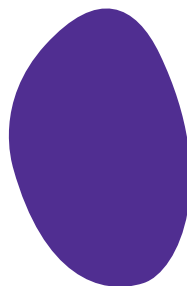

BenQ Organic Shape 4
BenQ_OrgShape_4_CMYK.eps



BenQ Organic Shape 5
BenQ_OrgShape_5_CMYK.eps

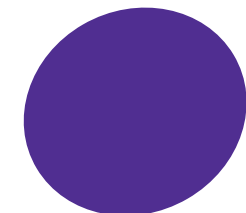

BenQ Organic Shape 6
BenQ_OrgShape_6_CMYK.eps



C 01.04 VI Elements Organic Wave Bar

Master Shapes

The Organic Wave Bar has been established for use on print, advertising, point of sale, retail and exhibition items. These shapes may be used to mask specified patterns and product imagery.

The wave bar is derived from the base of a flipped and reversed version of the BenQ Logo Organic Shape. See diagrams below.

The wave bar has been established for use on all applications. The artwork for the wave bar is available in electronic vector format.



BenQ Organic Wave bar
BenQ_WaveBar_CMYK.ai

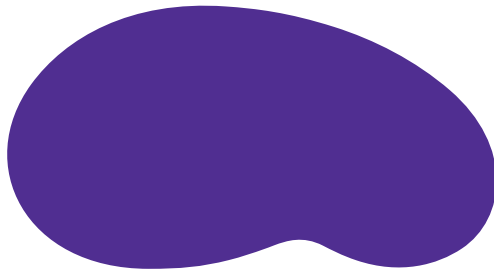

BenQ Logo Organic Shape
BENQ_OrganicShape.ai

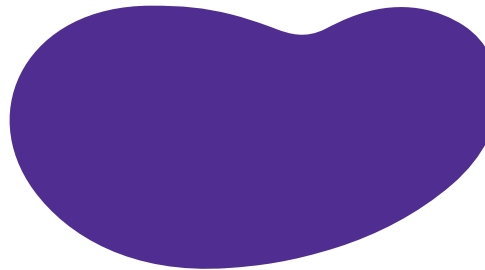

BenQ Logo Organic Shape is
flipped Vertically and Horizontally

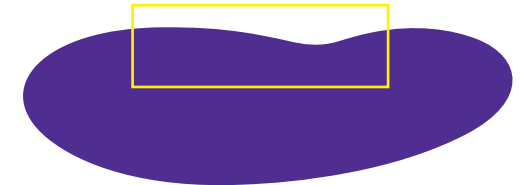

BenQ Logo Organic Shape
and vertically reduced by 60%



C 01.05 VI Elements Corporate VI Pattern One Wing

BenQ Corporate One Wing Pattern

BenQ Corporate One Wing Pattern has been designed for use on all corporate, product and promotional items.

These patterns may be masked, rotated, flipped or reproduced full bleed on brochures and packaging. They may be used in conjunction with the organic wave bar as specified in the BenQ Advertising guidelines and in accordance with specific application as shown in these guidelines.

The Corporate Pattern is for use on corporate and branding items.

The specifications on the following pages must be strictly adhered to when applying these patterns.

The artwork for these patterns are available in electronic PMS, CMYK and RGB format, and as a layered file. Each Corporate Pattern has been created with a lighter version (Lt) more suitable for use in backgrounds.

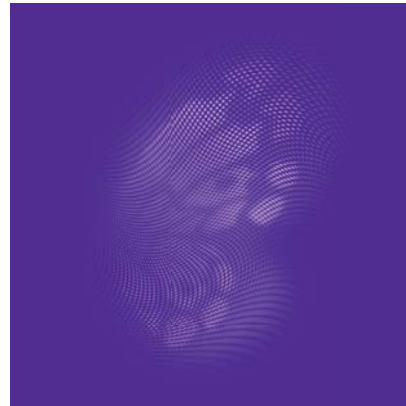

Purple

PMS
BenQ_IW_PMS_Lg.psd
BenQ_IW_PMS_Md.psd
BenQ_IW_P_PMS_Sm.psd
CMYK
BenQ_IW_CMYK_Lay.psd
BenQ_IW_CMYK_Lg.psd
BenQ_IW_CMYK_Md.psd
BenQ_IW_CMYK_Sm.psd
RGB
BenQ_IW_RGB_Lg.jpg
BenQ_IW_RGB_Md.jpg
BenQ_IW_RGB_Sm.jpg



Purple Light (P)

PMS
BenQ_IW_Lt_PMS_Lg.psd
BenQ_IW_Lt_PMS_Md.psd
BenQ_IW_Lt_PMS_Sm.psd
CMYK
BenQ_IW_Lt_CMYK_Lay.psd
BenQ_IW_Lt_CMYK_Lg.psd
BenQ_IW_Lt_CMYK_Md.psd
BenQ_IW_Lt_CMYK_Sm.psd
RGB
BenQ_IW_Lt_RGB_Lg.jpg
BenQ_IW_Lt_RGB_Md.jpg
BenQ_IW_Lt_RGB_Sm.jpg

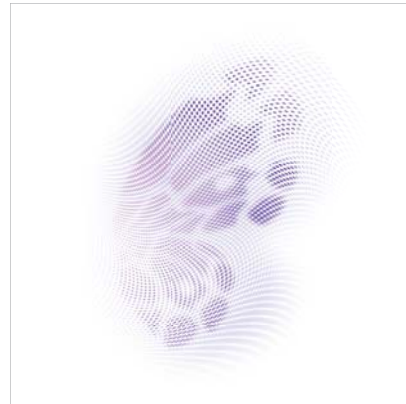

Purple Reversed (P)

PMS
BenQ_IW_Rev_PMS_Lg.psd
BenQ_IW_Rev_PMS_Md.psd
BenQ_IW_Rev_PMS_Sm.psd
CMYK
BenQ_IW_Rev_CMYK_Lay.psd
BenQ_IW_Rev_CMYK_Lg.psd
BenQ_IW_Rev_CMYK_Md.psd
BenQ_IW_Rev_CMYK_Sm.psd
RGB
BenQ_IW_Rev_RGB_Lg.jpg
BenQ_IW_Rev_RGB_Md.jpg
BenQ_IW_Rev_RGB_Sm.jpg

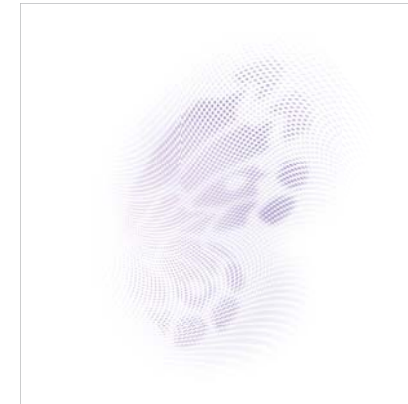

Purple Light Reversed (P)

PMS
BenQ_IW_Rev_Lt_PMS_Lg.psd
BenQ_IW_Rev_Lt_PMS_Md.psd
BenQ_IW_Rev_Lt_PMS_Sm.psd
CMYK
BenQ_IW_Rev_Lt_CMYK_Lay.psd
BenQ_IW_Rev_Lt_CMYK_Lg.psd
BenQ_IW_Rev_Lt_CMYK_Md.psd
BenQ_IW_Rev_Lt_CMYK_Sm.psd
RGB
BenQ_IW_Rev_Lt_RGB_Lg.jpg
BenQ_IW_Rev_Lt_RGB_Md.jpg
BenQ_IW_Rev_Lt_RGB_Sm.jpg



C 01.06 VI Elements Corporate VI Pattern Two Wing

BenQ Corporate Two Wing Pattern

BenQ Corporate Two Wing Pattern has been designed for use on all corporate, product and promotional items.

These patterns may be masked, rotated, flipped or reproduced full bleed on brochures and packaging. They may be used in conjunction with the organic wave bar as specified in the BenQ Advertising guidelines and in accordance with specific application as shown in these guidelines.

The Corporate Pattern is for use on corporate and branding items.

The specifications on the following pages must be strictly adhered to when applying these patterns.

The artwork for these patterns are available in electronic PMS, CMYK and RGB format, and as a layered file. Each Corporate Pattern has been created with a lighter version (Lt) more suitable for use in backgrounds.

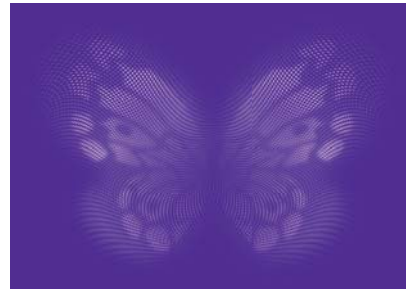

Purple

PMS
BenQ_2W_PMS_Lg.psd
BenQ_2W_PMS_Md.psd
BenQ_2W_P_PMS_Sm.psd
CMYK
BenQ_2W_CMYK_Lay.psd
BenQ_2W_CMYK_Lg.psd
BenQ_2W_CMYK_Md.psd
BenQ_2W_CMYK_Sm.psd
RGB
BenQ_2W_RGB_Lg.jpg
BenQ_2W_RGB_Md.jpg
BenQ_2W_RGB_Sm.jpg

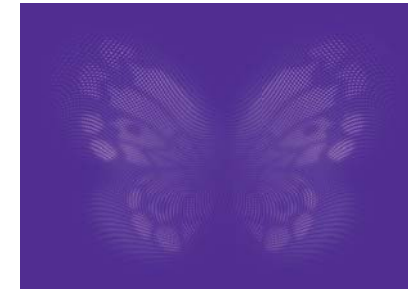

Purple Light (P)

PMS
BenQ_2W_Lt_PMS_Lg.psd
BenQ_2W_Lt_PMS_Md.psd
BenQ_2W_Lt_PMS_Sm.psd
CMYK
BenQ_2W_Lt_CMYK_Lay.psd
BenQ_2W_Lt_CMYK_Lg.psd
BenQ_2W_Lt_CMYK_Md.psd
BenQ_2W_Lt_CMYK_Sm.psd
RGB
BenQ_2W_Lt_RGB_Lg.jpg
BenQ_2W_Lt_RGB_Md.jpg
BenQ_2W_Lt_RGB_Sm.jpg

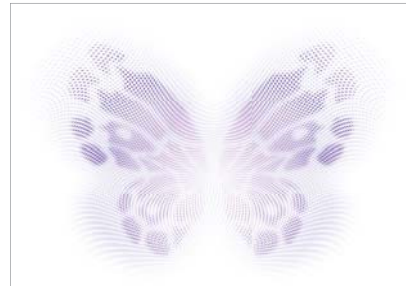

Purple Reversed (P)

PMS
BenQ_2W_Rev_PMS_Lg.psd
BenQ_2W_Rev_PMS_Md.psd
BenQ_2W_Rev_PMS_Sm.psd
CMYK
BenQ_2W_Rev_CMYK_Lay.psd
BenQ_2W_Rev_CMYK_Lg.psd
BenQ_2W_Rev_CMYK_Md.psd
BenQ_2W_Rev_CMYK_Sm.psd
RGB
BenQ_2W_Rev_RGB_Lg.jpg
BenQ_2W_Rev_RGB_Md.jpg
BenQ_2W_Rev_RGB_Sm.jpg

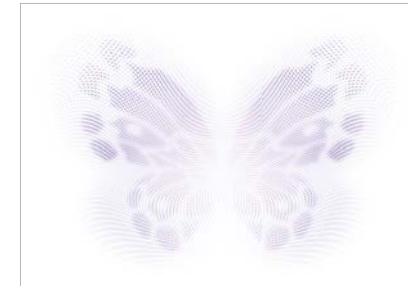

Purple Light Reversed (P)

PMS
BenQ_2W_Rev_Lt_PMS_Lg.psd
BenQ_2W_Rev_Lt_PMS_Md.psd
BenQ_2W_Rev_Lt_PMS_Sm.psd
CMYK
BenQ_2W_Rev_Lt_CMYK_Lay.psd
BenQ_2W_Rev_Lt_CMYK_Lg.psd
BenQ_2W_Rev_Lt_CMYK_Md.psd
BenQ_2W_Rev_Lt_CMYK_Sm.psd
RGB
BenQ_2W_Rev_Lt_RGB_Lg.jpg
BenQ_2W_Rev_Lt_RGB_Md.jpg
BenQ_2W_Rev_Lt_RGB_Sm.jpg



C 01.07VI Elements

Corporate VI Pattern Two Wing Extended

BenQ Corporate Pattern Two Wing Extended

BenQ Corporate Two Wing Extended Pattern has been designed for use on all corporate, product and promotional items.

These patterns may be masked, rotated, flipped or reproduced full bleed on brochures and packaging. They may be used in conjunction with the organic wave bar as specified in the BenQ Advertising guidelines and in accordance with specific application as shown in these guidelines.

The Corporate Pattern is for use on corporate and branding items.

The specifications on the following pages must be strictly adhered to when applying these patterns.

The artwork for these patterns are available in electronic PMS, CMYK and RGB format, and as a layered file. Each Corporate Pattern has been created with a lighter version (Lt) more suitable for use in backgrounds.

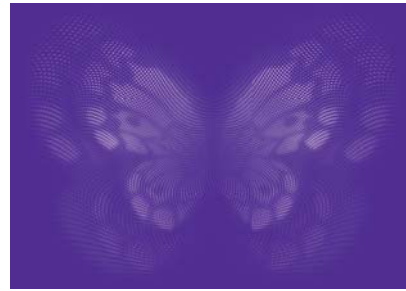

Purple

- PMS**
- BenQ_2W_Ex_PMS_Lg.psd
- BenQ_2W_Ex_PMS_Md.psd
- BenQ_2W_Ex_P_PMS_Sm.psd
- CMYK**
- BenQ_2W_Ex_CMYK_Lay.psb
- BenQ_2W_Ex_CMYK_Lg.psd
- BenQ_2W_Ex_CMYK_Md.psd
- BenQ_2W_Ex_CMYK_Sm.psd
- RGB**
- BenQ_2W_Ex_RGB_Lg.jpg
- BenQ_2W_Ex_RGB_Md.jpg
- BenQ_2W_Ex_RGB_Sm.jpg

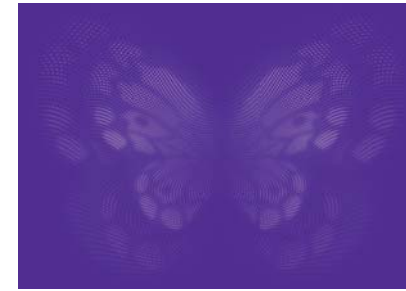

Purple Light (P)

- PMS**
- BenQ_2W_Ex_Lt_PMS_Lg.psd
- BenQ_2W_Ex_Lt_PMS_Md.psd
- BenQ_2W_Ex_Lt_PMS_Sm.psd
- CMYK**
- BenQ_2W_Ex_Lt_CMYK_Lay.psb
- BenQ_2W_Ex_Lt_CMYK_Lg.psd
- BenQ_2W_Ex_Lt_CMYK_Md.psd
- BenQ_2W_Ex_Lt_CMYK_Sm.psd
- RGB**
- BenQ_2W_Ex_Lt_RGB_Lg.jpg
- BenQ_2W_Ex_Lt_RGB_Md.jpg
- BenQ_2W_Ex_Lt_RGB_Sm.jpg



Purple Reversed (P)

- PMS**
- BenQ_2W_Ex_Rev_PMS_Lg.psd
- BenQ_2W_Ex_Rev_PMS_Md.psd
- BenQ_2W_Ex_Rev_PMS_Sm.psd
- CMYK**
- BenQ_2W_Ex_Rev_CMYK_Lay.psb
- BenQ_2W_Ex_Rev_CMYK_Lg.psd
- BenQ_2W_Ex_Rev_CMYK_Md.psd
- BenQ_2W_Ex_Rev_CMYK_Sm.psd
- RGB**
- BenQ_2W_Ex_Rev_RGB_Lg.jpg
- BenQ_2W_Ex_Rev_RGB_Md.jpg
- BenQ_2W_Ex_Rev_RGB_Sm.jpg

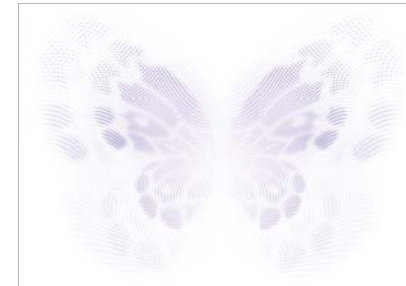

Purple Light Reversed (P)

- PMS**
- BenQ_2W_Ex_Rev_Lt_PMS_Lg.psd
- BenQ_2W_Ex_Rev_Lt_PMS_Md.psd
- BenQ_2W_Ex_Rev_Lt_PMS_Sm.psd
- CMYK**
- BenQ_2W_Ex_Rev_Lt_CMYK_Lay.psb
- BenQ_2W_Ex_Rev_Lt_CMYK_Lg.psd
- BenQ_2W_Ex_Rev_Lt_CMYK_Md.psd
- BenQ_2W_Ex_Rev_Lt_CMYK_Sm.psd
- RGB**
- BenQ_2W_Ex_Rev_Lt_RGB_Lg.jpg
- BenQ_2W_Ex_Rev_Lt_RGB_Md.jpg
- BenQ_2W_Ex_Rev_Lt_RGB_Sm.jpg



C 01.08VI Elements Cropping Guide for the Corporate Pattern

Sections of the patterns may be rotated and cropped, to apply to corporate collateral and marketing materials. These diagrams demonstrate examples of possible croppings. The area bounded by the yellow line indicates the cropped area example.

The pattern should burst from a corner or an edge. The pattern crop must allow enough non pattern area to hold type.

This system of cropping also applies to all BenQ Patterns.

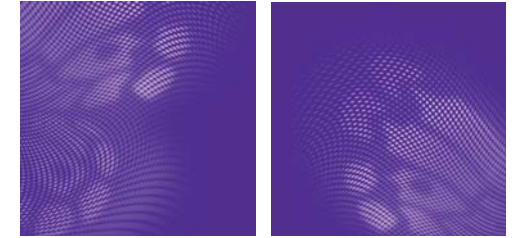
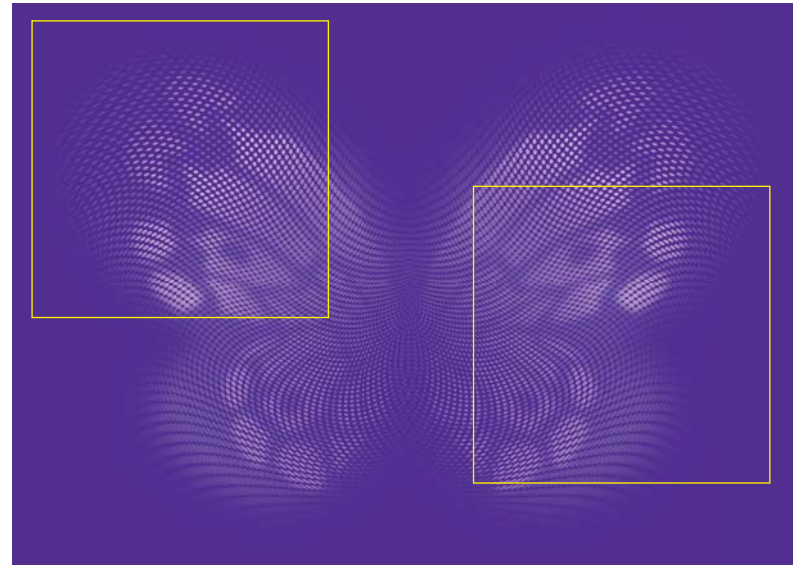

The pattern should burst from a corner or an edge.





C 01.09 VI Elements Cropping Guide for the Corporate Pattern Continued

Sections of the patterns may be rotated and cropped, to apply to corporate collateral and marketing materials. These diagrams demonstrate examples of possible croppings. The area bounded by the yellow line indicates the cropped area example.

The pattern should burst from a corner or an edge. The pattern crop must allow enough non pattern area to hold type.

This system of cropping also applies to all BenQ Patterns.

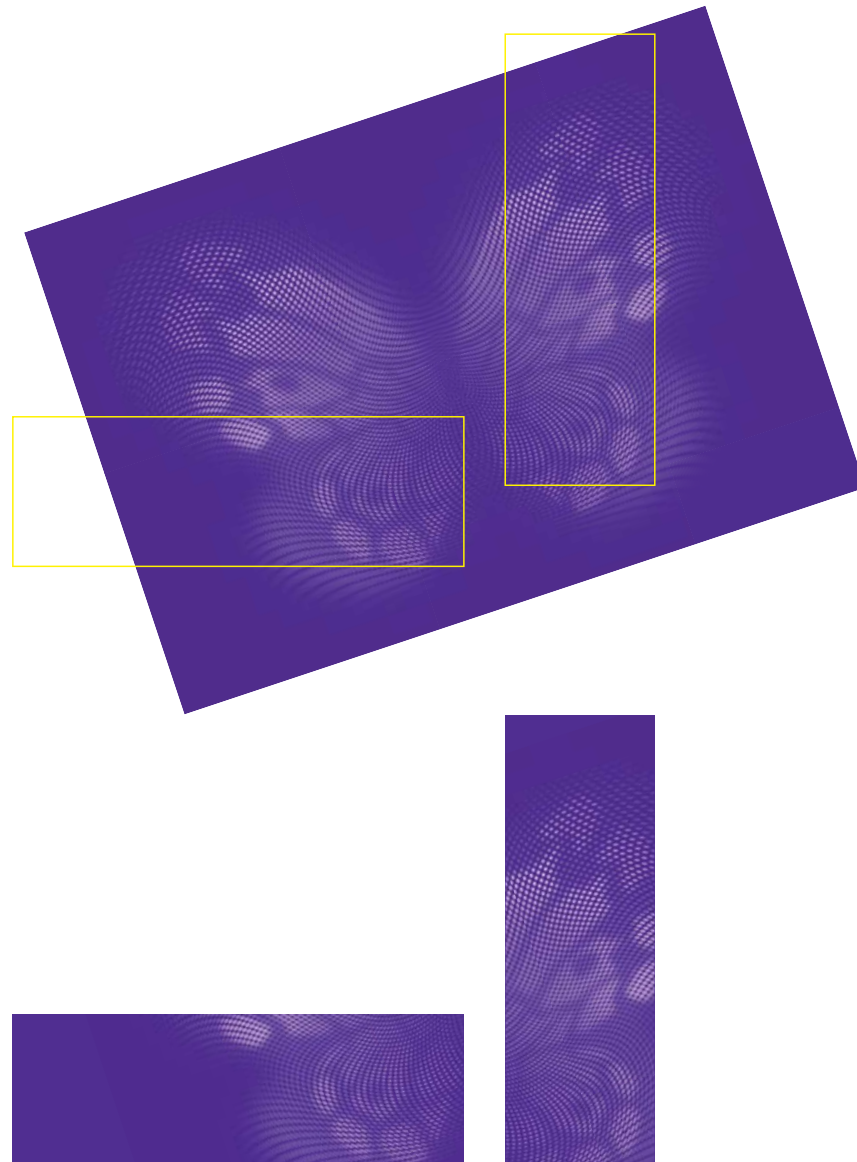



C 01.10VI Elements Vertical Cropping Guide for the Corporate Pattern

The BenQ patterns may be cropped for use on print, advertising, point of sale, retail, exhibition and packaging items. A cropping guide has been supplied to assist in cropping sections for use on vertical items. Croppings are best done as set proportions.

Scale of the pattern may vary within the same proportion. These diagrams demonstrate examples of possible croppings.

This system of cropping applies to all BenQ Patterns.



1:1



1:2



1:2



1:3



1:4



C 01.11 VI Elements Horizontal Cropping Guide for the Corporate Pattern

The BenQ patterns may be cropped for use on print, advertising, point of sale, retail, exhibition and packaging items. A cropping guide has been supplied to assist in cropping sections for use on horizontal items. Croppings are best done as set proportions.

Scale of the pattern may vary within the same proportion. These diagrams demonstrate examples of possible croppings.

This system of cropping applies to all BenQ Patterns.



1:2



1:3



1:4



1:5



1:12



C 01.12VI Elements Vertical Cropping Guide for the Corporate Pattern Reversed

The BenQ patterns may be cropped for use on print, advertising, point of sale, retail, exhibition and packaging items. A cropping guide has been supplied to assist in cropping sections for use on vertical items. Croppings are best done as set proportions.

Scale of the pattern may vary within the same proportion. These diagrams demonstrate examples of possible croppings.

This system of cropping applies to all BenQ Patterns.



1:1



1:2

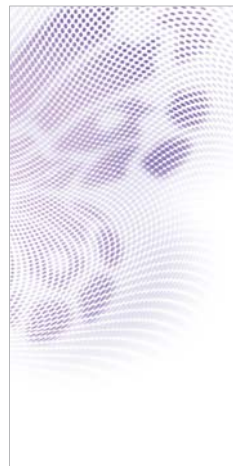

1:2



1:3



1:4



C 01.13 VI Elements Horizontal Cropping Guide for the Corporate Pattern Reversed

The BenQ patterns may be cropped for use on print, advertising, point of sale, retail, exhibition and packaging items. A cropping guide has been supplied to assist in cropping sections for use on horizontal items. Croppings are best done as set proportions.

Scale of the pattern may vary within the same proportion. These diagrams demonstrate examples of possible croppings.

This system of cropping applies to all BenQ Patterns.



1:2



1:3

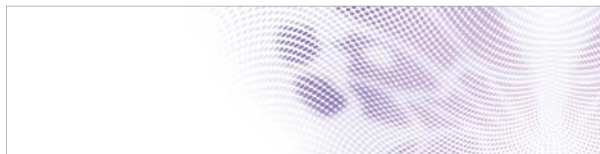

1:4

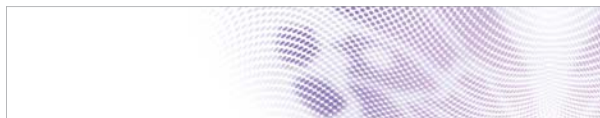

1:5



1:12



C 01.14VI Elements Corporate Pattern Incorrect Use

Incorrect use of the BenQ Corporate Patterns

Below are a few examples of incorrect usage of the Corporate Patterns.



repeated

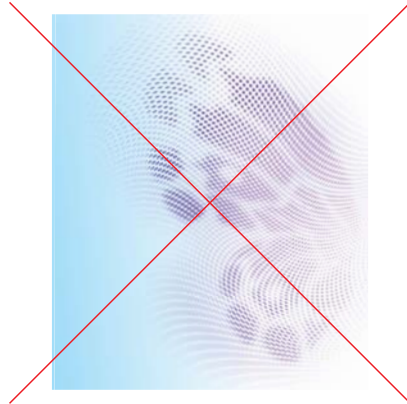

non-corporate
coloured gradients



non-corporate
coloured pattern



different scales
in several layers

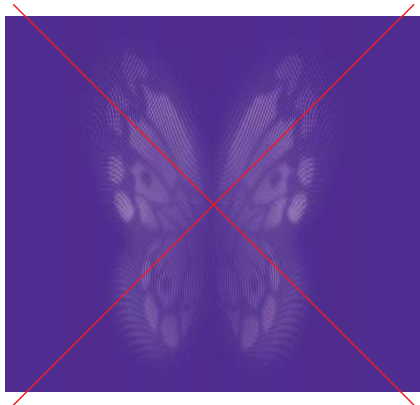

distorted

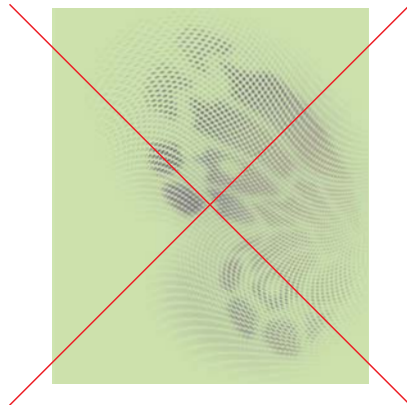

non-corporate
coloured backgrounds



placed directly over an image



place type over strong
section of pattern area



Corporate Identity and Visual Identity Guidelines
Section C 02
Stationery



C 02.01 Stationery Business Cards

Chinese Typography

Typeface Type size Line Space

Name
Microsoft JhengHei Bold 9 Point 11 Point

Title, Department
Microsoft JhengHei Regular 6 Point 8 Point

Company Details
Microsoft JhengHei Bold 9 Point 11 Point

Email and Web Address
Gill Sans MT Light 7 Point 9 Point

Numerals
Gill Sans MT Light 7 Point 9 Point

Alphabet Typography

Name
Gill Sans MT Regular 10 Point 12 Point

Company Name
Gill Sans MT Regular 10 Point 12 Point

Company Details
Gill Sans MT Light 7 Point 9 Point



Size

90mm x 55mm

Stock

Brilliant White, good quality card 300gsm
i.e. Saxton Smooth.

Colour

Logo, pattern and type printed
four colour process.

Pattern

Use the Corporate Pattern Reversed .psd files.

Note

For all languages the Name, Title and
Department Name must not exceed 4 lines.



BenQ Purple
PMS 268



PMS 432U



C 02.02 Stationery Letterhead

Size

210mm x 297mm
210mm x 280mm

Stock

Brilliant White, good quality smooth paper.
i.e. Saxton Smooth, 100gsm. No watermark.

BenQ Company Details

Gill Sans MT Light and Regular,
8 point, 10 point line spacing.

Cropping Guide

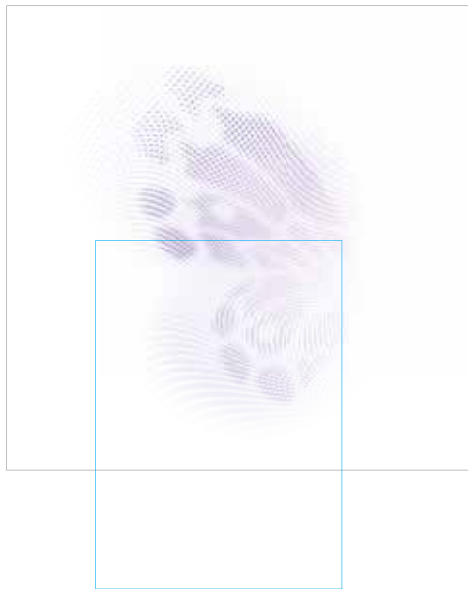

BenQ_1W_Rev_Lt_CMYK_Md.psd

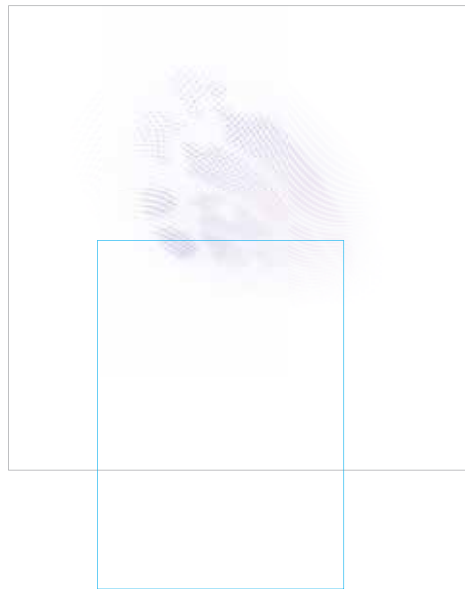

BenQ_1W_Rev_Lt_CMYK_St_Md.psd

Colour

Logo, pattern and type printed
four colour process.

Pattern

Please ensure that the
stationery pattern is used
BenQ_1W_Rev_Lt_CMYK_St_Md.psd

This layout allows for one, two or three
addresses.

	25		28	20	
40					11
		Month 00 2011	BenQ Corporation		19
		Name of Person	Headquarters		10
		Title of Person	16 Jhu Rd, Neihu Taipei 114		9
		Company	Taiwan ROC		20.5
		Street Address	Telephone +886 2 2658 8880		29.5
		Suburb City State	Facsimile +886 2 2797 9288		
		Country	BenQ.com		
		Dear Person			
		Subject Title			
		The application of a neat and consistent typing format enhances the design of stationery items and complements the image of the company.			Fold The top of the address is the fold point for the letter.
		The top margin of this letter should align left with a margin of 2.5cm. The top margin should be set at 4cm and the right-hand margin at 2cm. The typeface is Gill Sans MT and the point size is 8 point with 10 point line spacing. All lines should be typed using single line spacing, ranged left, avoiding the use of hyphenation. Paragraphs should not be indented, but separated by one line space.			
		Start the letter with the date followed by the name and address two line space below it. Allow ten line spaces between the first line of the name and address and the salutation to ensure a consistent starting point.			
		If a subject title is required it should start four line spaces below the salutation. If no subject title is required then the body of the letter should start one line space below the salutation.			
		If your letter comes within 5cm of the foot of the page, use a continuation sheet. Ensure at least five lines, excluding the signature, are carried over. Do not split the paragraph over the page. Take the whole paragraph to the next page. Type the closure three line spaces below the body of the letter and the name of the signatory and his/her title if required, five line spaces below the closure.			
		Labortile facipismodio conullaore eugue min vel in henim veniscilism dolesto con ulputet lummy nisi illisid scidunt la feugait prat. Ro odo conum et ing ex exeriere conse feum venim dit iurem doloreet nulla alit prat, si. Dunt velendrer secte tat luptat ad tate magnisit la facillit, quis eu faccumy nosto ea feugait nullum verostinisi dolobor illa commodolor iureet laor sit wis esecte veriuercit tat utet ut del ut at ver ad estrud tio dipismo lobore min henim quat.			
		Yours sincerely			Fold The top of the address is the fold point for the letter.
		Name of the Signatory			
		Title			
10					
	25		28	20	



BenQ Purple
PMS 268



C 02.03 Stationery Letterhead A4

A4 210mm x 297mm Three Address Format

11



BenQ Corporation

Headquarters
157 Shun-ying Rd, Guoshun
Taoyuan 333, Taiwan ROC
Telephone: +886 3 359 5000
Facsimile: +886 3 2359 9000

Headquarters
16 Jhu Rd, Neihu Taipei 114
Taiwan ROC
Telephone: +886 2 2658 8880
Facsimile: +886 2 2797 9288
Hsinchu Business Center
23 Ushin Rd, Hsinchu Science Park
Hsinchu 300, Taiwan ROC
Telephone: +886 3 611 8800
Facsimile: +886 3 611 8822
BenQ.com

Month 00 2011

Name of Person
Title of Person
Company
Street Address
Suburb City State
Country

Dear Person

Subject Title

The application of a neat and consistent typing format enhances the design of stationery items and complements the image of the company.

The typing format of this letter should align left with a margin of 2.5cm. The top margin should be set at 4cm and the right-hand margin at 2cm. The typeface is Gill Sans MT and the point size is 8 point with 10 point line spacing. All lines should be typed using single line spacing, ranged left, avoiding the use of hyphenation. Paragraphs should not be indented, but separated by one line space.

Start the letter with the date followed by the name and address two line space below it. Allow ten line spaces between the first line of the name and address and the salutation to ensure a consistent starting point.

If a subject title is required it should start four line spaces below the salutation. If no subject title is required then the body of the letter should start one line space below the salutation.

If your letter comes within 5cm of the foot of the page, use a continuation sheet. Ensure at least five lines, excluding the signature, are carried over. Do not split the paragraph over the page. Take the whole paragraph to the next page. Type the closure three line spaces below the body of the letter and the name of the signatory and his/her title if required, five line spaces below the closure.

Lobortie facipismodio conullaore eugue min vel in henim venicilism dolesto con upatet lummy nisi illisi scidunt la feugiat pret. Ro odo conum et ing ox exeritue conse feum venim diti larem doloret nulla aili prat. si. Dunt velendrer secte lat laptat ad tate magnisit la facilii, quis eu faccummy nosto ea feugiat nullum verostitisi dolobor illa commodolor kureet laor sit wts essecte verurercerit tat utet aut del ut at ver ad estrud to dipismo lobore min henim quat.

Yours sincerely

Name of the Signatory
Title

10

25

A4 210mm x 297mm Two Address Format

11



BenQ Corporation

Headquarters
157 Shun-ying Rd, Guoshun
Taoyuan 333, Taiwan ROC
Telephone: +886 3 359 5000
Facsimile: +886 3 2359 9000

Headquarters
16 Jhu Rd, Neihu Taipei 114
Taiwan ROC
Telephone: +886 2 2658 8880
Facsimile: +886 2 2797 9288
BenQ.com

Month 00 2011

Name of Person
Title of Person
Company
Street Address
Suburb City State
Country

Dear Person

Subject Title

The application of a neat and consistent typing format enhances the design of stationery items and complements the image of the company.

The typing format of this letter should align left with a margin of 2.5cm. The top margin should be set at 4cm and the right-hand margin at 2cm. The typeface is Gill Sans MT and the point size is 8 point with 10 point line spacing. All lines should be typed using single line spacing, ranged left, avoiding the use of hyphenation. Paragraphs should not be indented, but separated by one line space.

Start the letter with the date followed by the name and address two line space below it. Allow ten line spaces between the first line of the name and address and the salutation to ensure a consistent starting point.

If a subject title is required it should start four line spaces below the salutation. If no subject title is required then the body of the letter should start one line space below the salutation.

If your letter comes within 5cm of the foot of the page, use a continuation sheet. Ensure at least five lines, excluding the signature, are carried over. Do not split the paragraph over the page. Take the whole paragraph to the next page. Type the closure three line spaces below the body of the letter and the name of the signatory and his/her title if required, five line spaces below the closure.

Lobortie facipismodio conullaore eugue min vel in henim venicilism dolesto con upatet lummy nisi illisi scidunt la feugiat pret. Ro odo conum et ing ox exeritue conse feum venim diti larem doloret nulla aili prat. si. Dunt velendrer secte lat laptat ad tate magnisit la facilii, quis eu faccummy nosto ea feugiat nullum verostitisi dolobor illa commodolor kureet laor sit wts essecte verurercerit tat utet aut del ut at ver ad estrud to dipismo lobore min henim quat.

Yours sincerely

Name of the Signatory
Title

10

25

A4 210mm x 297mm Single Address Format

11



BenQ Corporation

Headquarters
157 Shun-ying Rd, Guoshun
Taoyuan 333, Taiwan ROC
Telephone: +886 3 359 5000
Facsimile: +886 3 2359 9000

Headquarters
16 Jhu Rd, Neihu Taipei 114
Taiwan ROC
Telephone: +886 2 2658 8880
Facsimile: +886 2 2797 9288
BenQ.com

Month 00 2011

Name of Person
Title of Person
Company
Street Address
Suburb City State
Country

Dear Person

Subject Title

The application of a neat and consistent typing format enhances the design of stationery items and complements the image of the company.

The typing format of this letter should align left with a margin of 2.5cm. The top margin should be set at 4cm and the right-hand margin at 2cm. The typeface is Gill Sans MT and the point size is 8 point with 10 point line spacing. All lines should be typed using single line spacing, ranged left, avoiding the use of hyphenation. Paragraphs should not be indented, but separated by one line space.

Start the letter with the date followed by the name and address two line space below it. Allow ten line spaces between the first line of the name and address and the salutation to ensure a consistent starting point.

If a subject title is required it should start four line spaces below the salutation. If no subject title is required then the body of the letter should start one line space below the salutation.

If your letter comes within 5cm of the foot of the page, use a continuation sheet. Ensure at least five lines, excluding the signature, are carried over. Do not split the paragraph over the page. Take the whole paragraph to the next page. Type the closure three line spaces below the body of the letter and the name of the signatory and his/her title if required, five line spaces below the closure.

Lobortie facipismodio conullaore eugue min vel in henim venicilism dolesto con upatet lummy nisi illisi scidunt la feugiat pret. Ro odo conum et ing ox exeritue conse feum venim diti larem doloret nulla aili prat. si. Dunt velendrer secte lat laptat ad tate magnisit la facilii, quis eu faccummy nosto ea feugiat nullum verostitisi dolobor illa commodolor kureet laor sit wts essecte verurercerit tat utet aut del ut at ver ad estrud to dipismo lobore min henim quat.

Yours sincerely

Name of the Signatory
Title

10

25



C 02.04 Stationery Letterhead US

US Letter 210mm x 280mm Three Address Format

US Letter 210mm x 280mm Two Address Format

US Letter 210mm x 280mm Single Address Format

11



BenQ Corporation

Headquarters
157 Shan-ying Rd, Guoshan
Taoyuan 333, Taiwan ROC
Telephone: +886 3 359 5000
Facsimile: +886 3 2359 9000

Headquarters
16 Jhu Rd, Neihu Taipei 114
Taiwan ROC
Telephone: +886 2 2658 8880
Facsimile: +886 2 2797 9288
Hsinchu Business Center
23 Ushiu Rd, Hsinchu Science Park
Hsinchu 300, Taiwan ROC
Telephone: +886 3 611 8800
Facsimile: +886 3 611 8822
BenQ.com

Month 00 2011

Name of Person
Title of Person
Company
Street Address
Suburb City State
Country

Dear Person

Subject Title

The application of a neat and consistent typing format enhances the design of stationery items and complements the image of the company.

The typing format of this letter should align left with a margin of 2.5cm. The top margin should be set at 4cm and the right-hand margin at 2cm. The typeface is Gill Sans MT and the point size is 8 point with 10 point line spacing. All lines should be typed using single line spacing, ranged left, avoiding the use of hyphenation. Paragraphs should not be indented, but separated by one line space.

Start the letter with the date followed by the name and address two line spaces below it. Allow ten line spaces between the first line of the name and address and the salutation to ensure a consistent starting point.

If a subject title is required it should start four line spaces below the salutation. If no subject title is required then the body of the letter should start one line space below the salutation.

If your letter comes within 5cm of the foot of the page, use a continuation sheet. Ensure at least five lines, excluding the signature, are carried over. Do not split the paragraph over the page. Take the whole paragraph to the next page. Type the closure three line spaces below the body of the letter and the name of the signatory and his/her title if required, five line spaces below the closure.

Lobortie facipismodio conullaore eugue min vel in henim venicillism dolesto con upatet lummy nisi illisi scidunt la feugiat prat. Ro odo conum et ing ox exerture conse feum venim diti larem doloret nulla aili prat. si Dunt velendrer secte lat laptat ad tate magnisit la facilii, quis eu faccummy nosto ea feugiat nullum verostitisi dolobor illa commodolor kureet laor sit wts lsecte verurercrri tat utet aut del ut at ver ad estrud to dipismo labore min henim quat.

Yours sincerely

Name of the Signatory
Title

10

25

11



BenQ Corporation

Headquarters
157 Shan-ying Rd, Guoshan
Taoyuan 333, Taiwan ROC
Telephone: +886 3 359 5000
Facsimile: +886 3 2359 9000

Headquarters
16 Jhu Rd, Neihu Taipei 114
Taiwan ROC
Telephone: +886 2 2658 8880
Facsimile: +886 2 2797 9288
BenQ.com

Month 00 2011

Name of Person
Title of Person
Company
Street Address
Suburb City State
Country

Dear Person

Subject Title

The application of a neat and consistent typing format enhances the design of stationery items and complements the image of the company.

The typing format of this letter should align left with a margin of 2.5cm. The top margin should be set at 4cm and the right-hand margin at 2cm. The typeface is Gill Sans MT and the point size is 8 point with 10 point line spacing. All lines should be typed using single line spacing, ranged left, avoiding the use of hyphenation. Paragraphs should not be indented, but separated by one line space.

Start the letter with the date followed by the name and address two line spaces below it. Allow ten line spaces between the first line of the name and address and the salutation to ensure a consistent starting point.

If a subject title is required it should start four line spaces below the salutation. If no subject title is required then the body of the letter should start one line space below the salutation.

If your letter comes within 5cm of the foot of the page, use a continuation sheet. Ensure at least five lines, excluding the signature, are carried over. Do not split the paragraph over the page. Take the whole paragraph to the next page. Type the closure three line spaces below the body of the letter and the name of the signatory and his/her title if required, five line spaces below the closure.

Lobortie facipismodio conullaore eugue min vel in henim venicillism dolesto con upatet lummy nisi illisi scidunt la feugiat prat. Ro odo conum et ing ox exerture conse feum venim diti larem doloret nulla aili prat. si Dunt velendrer secte lat laptat ad tate magnisit la facilii, quis eu faccummy nosto ea feugiat nullum verostitisi dolobor illa commodolor kureet laor sit wts lsecte verurercrri tat utet aut del ut at ver ad estrud to dipismo labore min henim quat.

Yours sincerely

Name of the Signatory
Title

10

25

11



BenQ Corporation

Headquarters
157 Shan-ying Rd, Guoshan
Taoyuan 333, Taiwan ROC
Telephone: +886 3 359 5000
Facsimile: +886 3 2359 9000

Headquarters
16 Jhu Rd, Neihu Taipei 114
Taiwan ROC
Telephone: +886 2 2658 8880
Facsimile: +886 2 2797 9288
BenQ.com

Month 00 2011

Name of Person
Title of Person
Company
Street Address
Suburb City State
Country

Dear Person

Subject Title

The application of a neat and consistent typing format enhances the design of stationery items and complements the image of the company.

The typing format of this letter should align left with a margin of 2.5cm. The top margin should be set at 4cm and the right-hand margin at 2cm. The typeface is Gill Sans MT and the point size is 8 point with 10 point line spacing. All lines should be typed using single line spacing, ranged left, avoiding the use of hyphenation. Paragraphs should not be indented, but separated by one line space.

Start the letter with the date followed by the name and address two line spaces below it. Allow ten line spaces between the first line of the name and address and the salutation to ensure a consistent starting point.

If a subject title is required it should start four line spaces below the salutation. If no subject title is required then the body of the letter should start one line space below the salutation.

If your letter comes within 5cm of the foot of the page, use a continuation sheet. Ensure at least five lines, excluding the signature, are carried over. Do not split the paragraph over the page. Take the whole paragraph to the next page. Type the closure three line spaces below the body of the letter and the name of the signatory and his/her title if required, five line spaces below the closure.

Lobortie facipismodio conullaore eugue min vel in henim venicillism dolesto con upatet lummy nisi illisi scidunt la feugiat prat. Ro odo conum et ing ox exerture conse feum venim diti larem doloret nulla aili prat. si Dunt velendrer secte lat laptat ad tate magnisit la facilii, quis eu faccummy nosto ea feugiat nullum verostitisi dolobor illa commodolor kureet laor sit wts lsecte verurercrri tat utet aut del ut at ver ad estrud to dipismo labore min henim quat.

Yours sincerely

Name of the Signatory
Title

10

25



C 02.05 Stationery Envelopes

Size

Although the envelope size may vary the Corporate Pattern size and positioning remain the same.

230mm x 116mm

274mm x 186mm

340mm x 260mm

Stock

Brilliant White, good quality smooth paper.
i.e. Saxton Smooth, 100gsm. No watermark.

BenQ Company Details

Gill Sans MT Light and Regular, 8 point, 10 point line spacing.

Colour

Logo, pattern and type printed four colour process.

Pattern

Please ensure that the stationery pattern is used
BenQ_1W_Rev_Lt_CMYK_St_Md.psd.

Cropping Guide

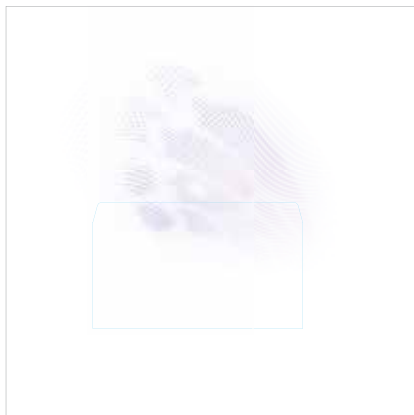

BenQ_1W_Rev_Lt_CMYK_St_Md.psd

230mm x 116mm

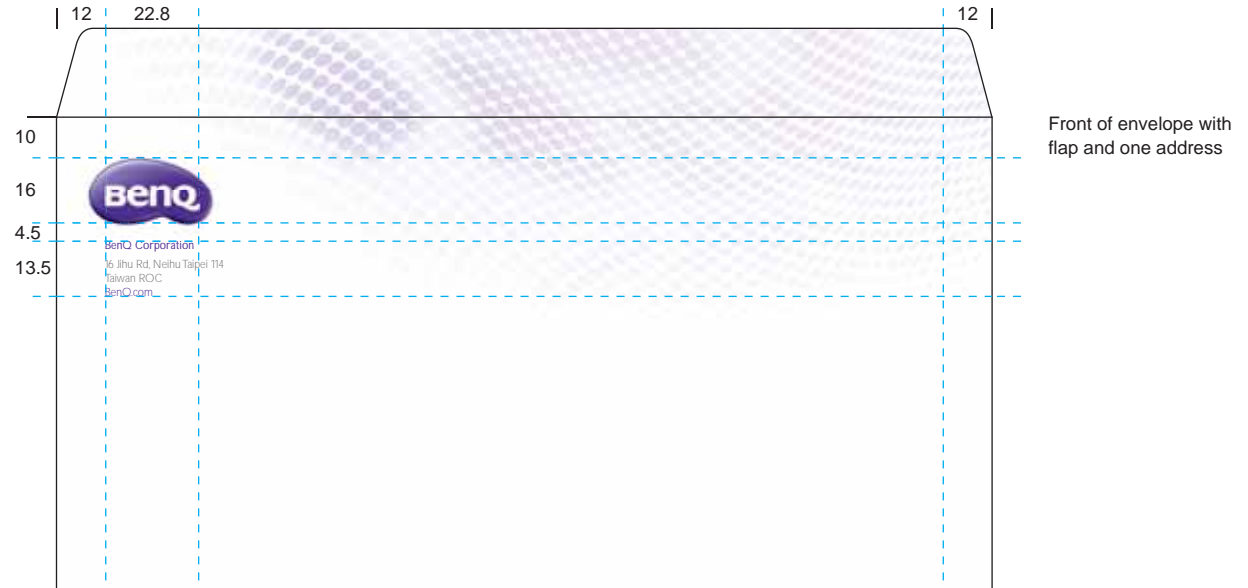

Front of envelope with flap and one address

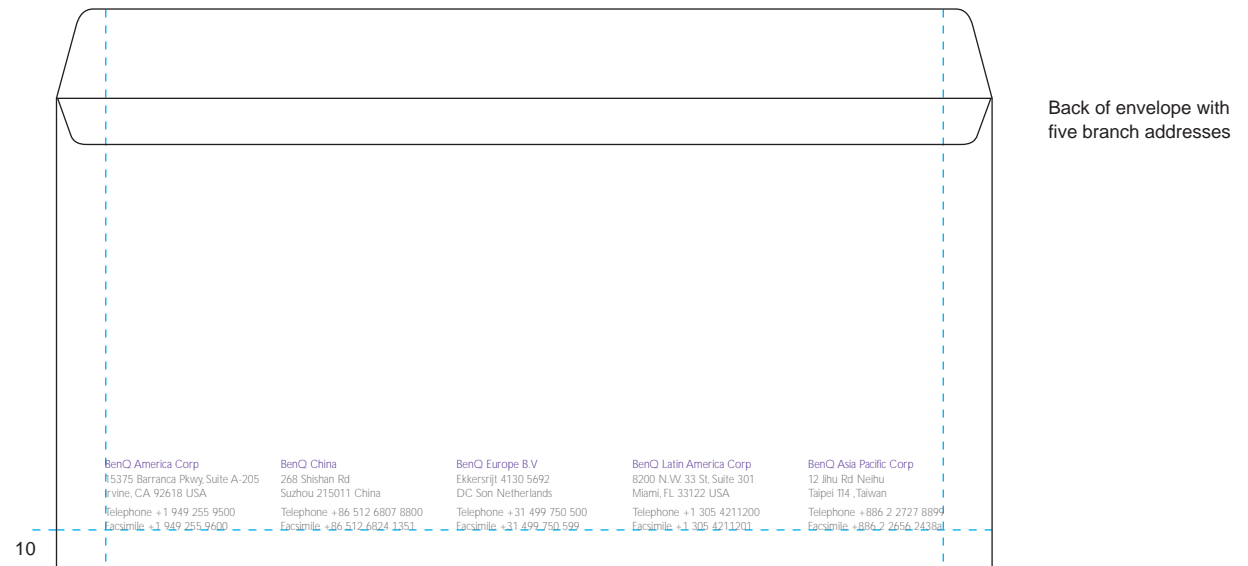

Back of envelope with five branch addresses



C 02.06 Stationery Envelopes Environmentally Friendly

Size

Although the envelope size may vary the Corporate Pattern size and positioning remain the same.

- 230mm x 116mm
- 274mm x 186mm
- 340mm x 260mm

Stock

Good quality recycled brown paper.

BenQ Company Details

Gill Sans MT Light and Regular,
8 point, 10 point line spacing.

Colour

Logo, type and pattern PMS 268.

Pattern

Please ensure that the stationery pattern is used
BenQ_1W_Rev_Lt_CMYK_St_Md.psd.

Cropping Guide

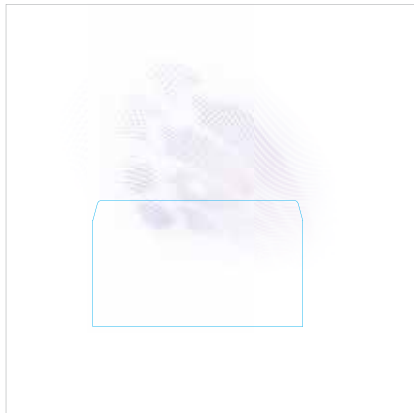

BenQ_1W_Rev_Lt_CMYK_St_Md.psd

230mm x 116mm

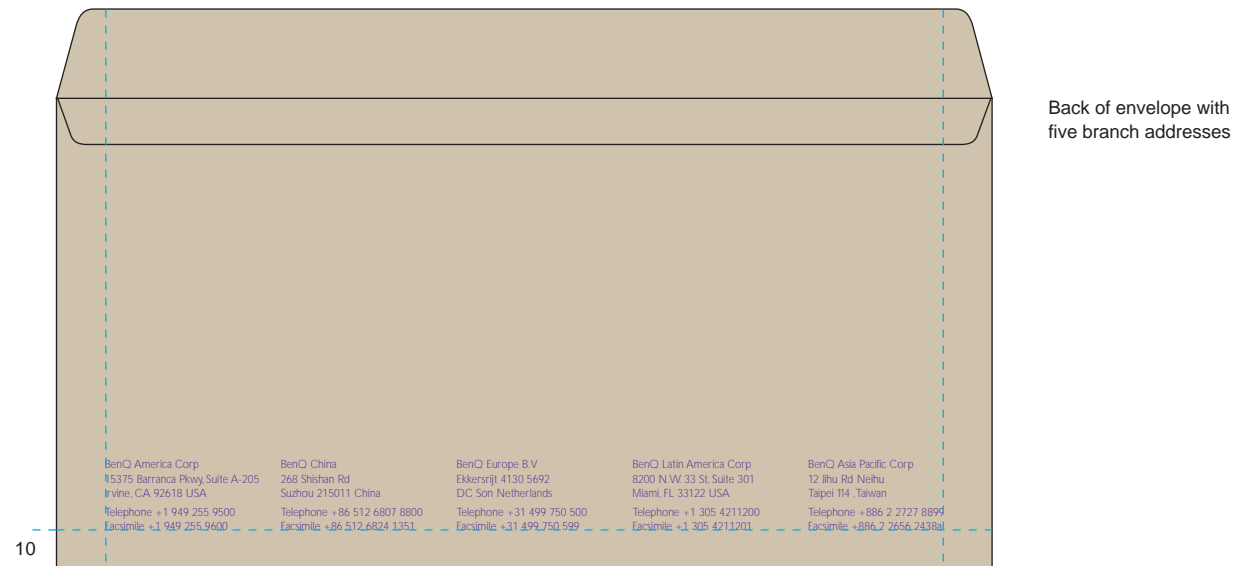
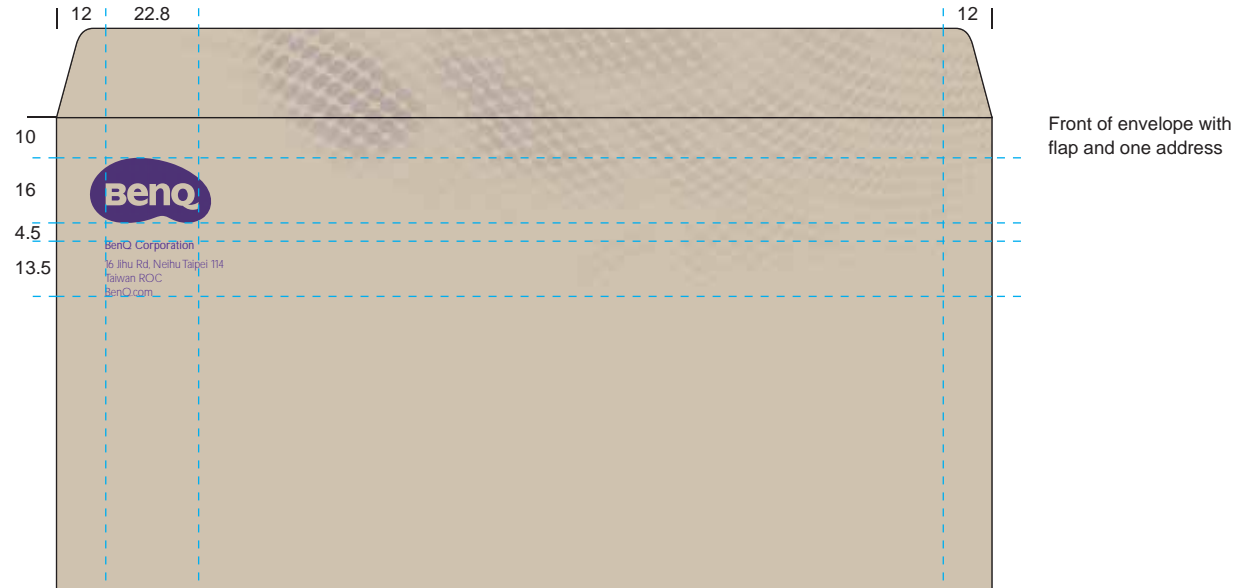



C 02.07 Stationery Envelopes Continued

Size

Although the envelope size may vary the Corporate Pattern size and positioning remain the same.

230mm x 116mm

274mm x 186mm

340mm x 260mm

BenQ Company Details

Gill Sans MT Light and Regular,

9 point, 11 point line spacing.

Stock Options

Refer to previous pages for stock variations.

Colour

Logo, pattern and type printed four colour process.

Pattern

Please ensure that the stationery pattern is used BenQ_1W_Rev_Lt_CMYK_St_Md.psd.

Cropping Guide

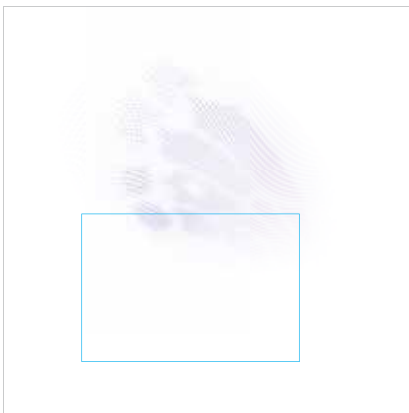

BenQ_1W_Rev_Lt_CMYK_St_Md.psd

274mm x 186mm

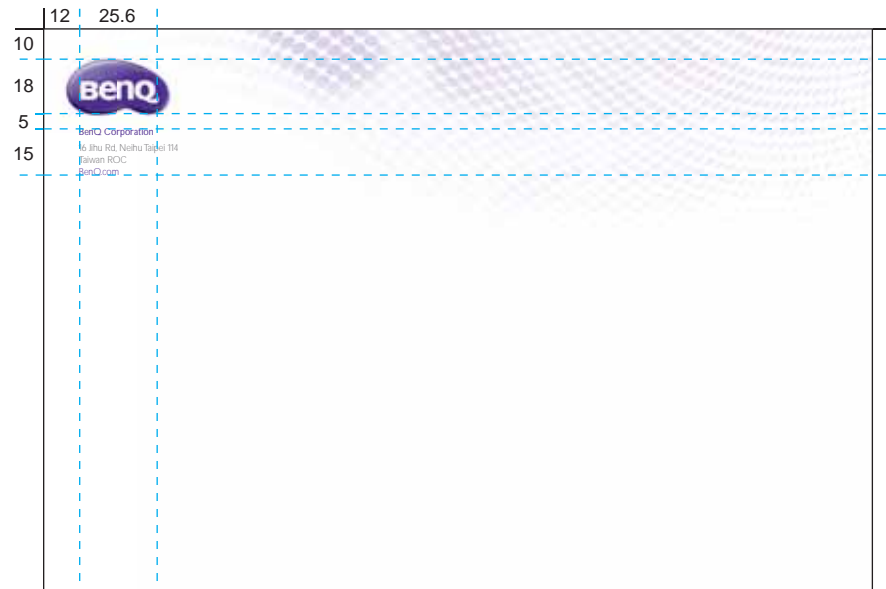

Front of envelope with flap and one address

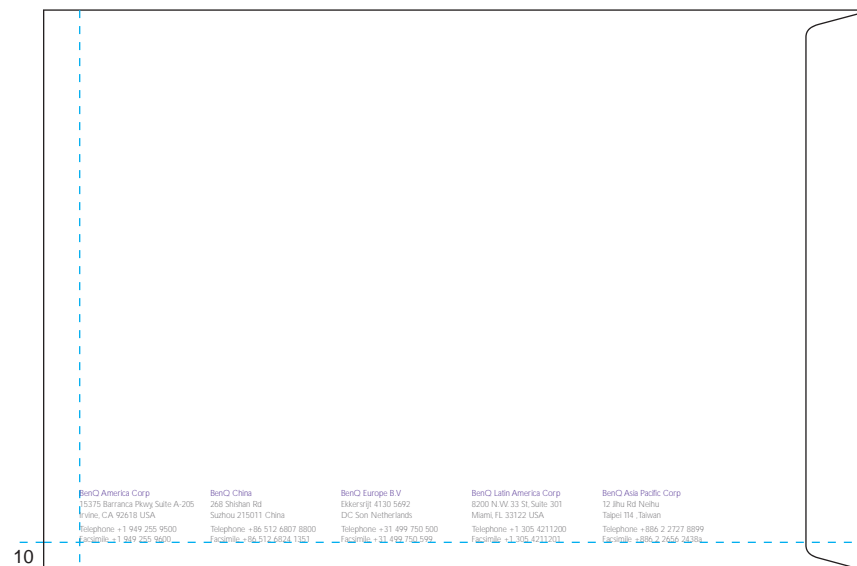

Back of envelope with five branch addresses



C 02.08 Stationery Envelopes Continued

Size

Although the envelope size may vary the Corporate Pattern size and positioning remain the same.

230mm x 116mm

274mm x 186mm

340mm x 260mm

BenQ Company Details

Gill Sans MT Light and Regular,
9 point, 11 point line spacing.

Stock Options

Refer to previous pages for stock variations.

Colour

Logo, pattern and type printed four colour process.

Pattern

Please ensure that the stationery pattern is used
BenQ_1W_Rev_Lt_CMYK_St_Md.psd.

Cropping Guide

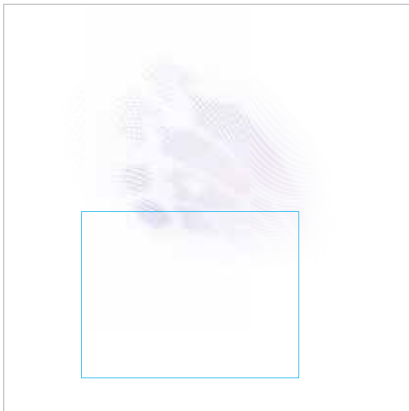

BenQ_1W_Rev_Lt_CMYK_St_Md.psd

340mm x 260mm

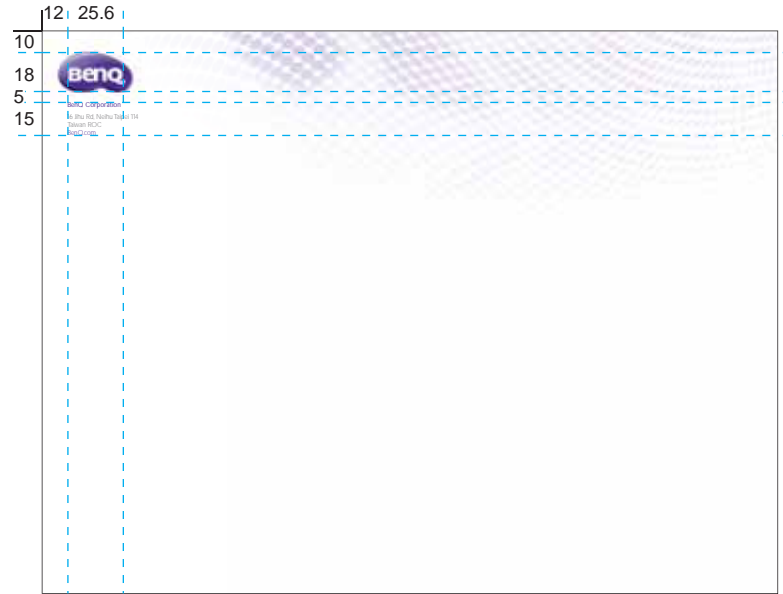

Front of envelope with flap and one address

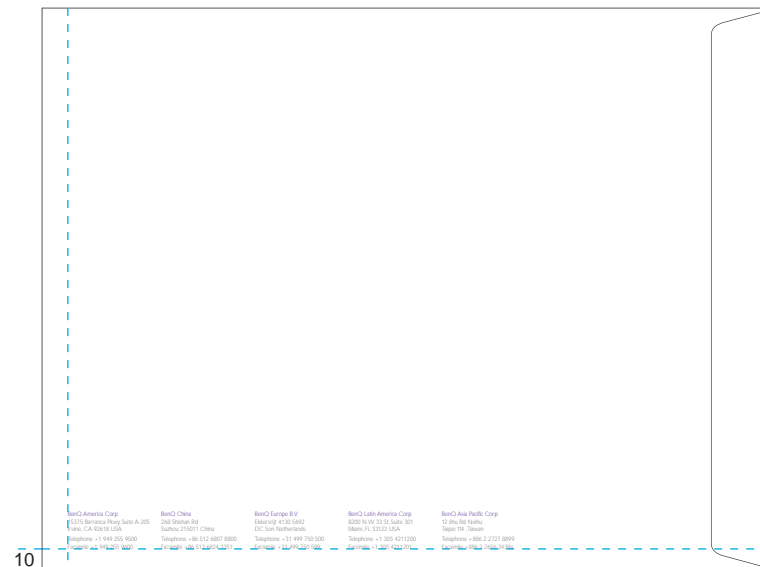

Back of envelope with five branch addresses



C 02.09 Stationery Presentation Folder

Size

230mm x 360mm finished.

Stock

Master Gloss or Black Velvet Artboard. 350gsm.
Seal with matt plastic film lamination.

Colour

The pattern and logo prints four colour process.
The inside is solid BenQ Purple PMS 268.

Pattern

Use the Corporate Pattern .psd file.

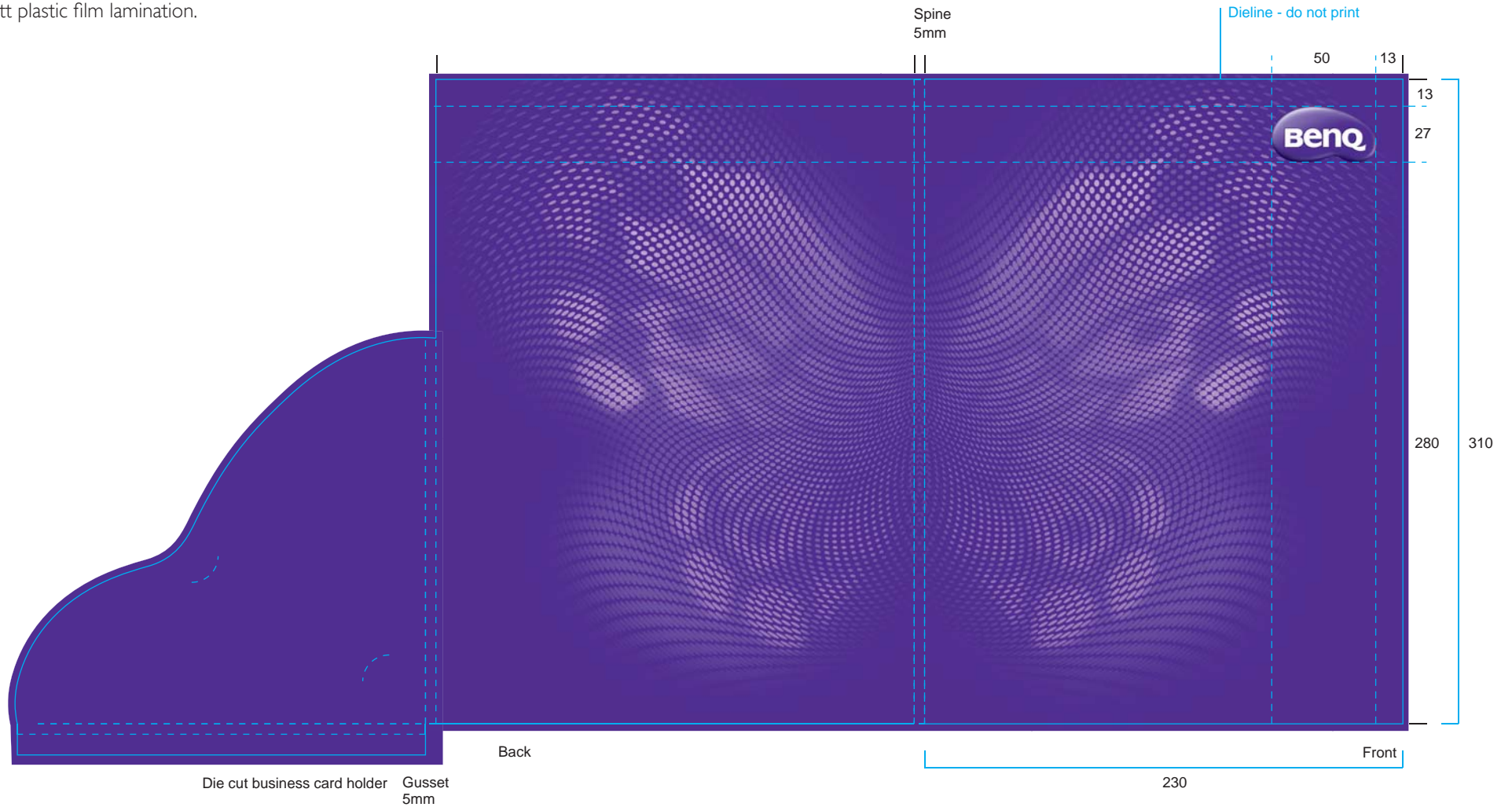



C 02.10 Stationery Presentation Folder Continued



By Su
Director
Brand Management Centre

BenQ

BenQ Corporation
16 Jhu Road, Neihu, Taipei 114, Taiwan
Telephone: +886 2 2658 8888 Ext 7231
Facsimile: +886 2 6602 6677
fo.su@benq.com BenQ.com

Pocket



C 02.11 Stationery Presentation Folder - Lever Arch or Ring Binder

Size

287mm x 315mm

Stock

Heavy folder card. Laminate print to card and seal with a matt Cellosheen.

Colour

The pattern and logo prints four colour process.
The inside is solid BenQ Purple PMS 268.

Pattern

Use the Corporate Pattern Extended .psd file.

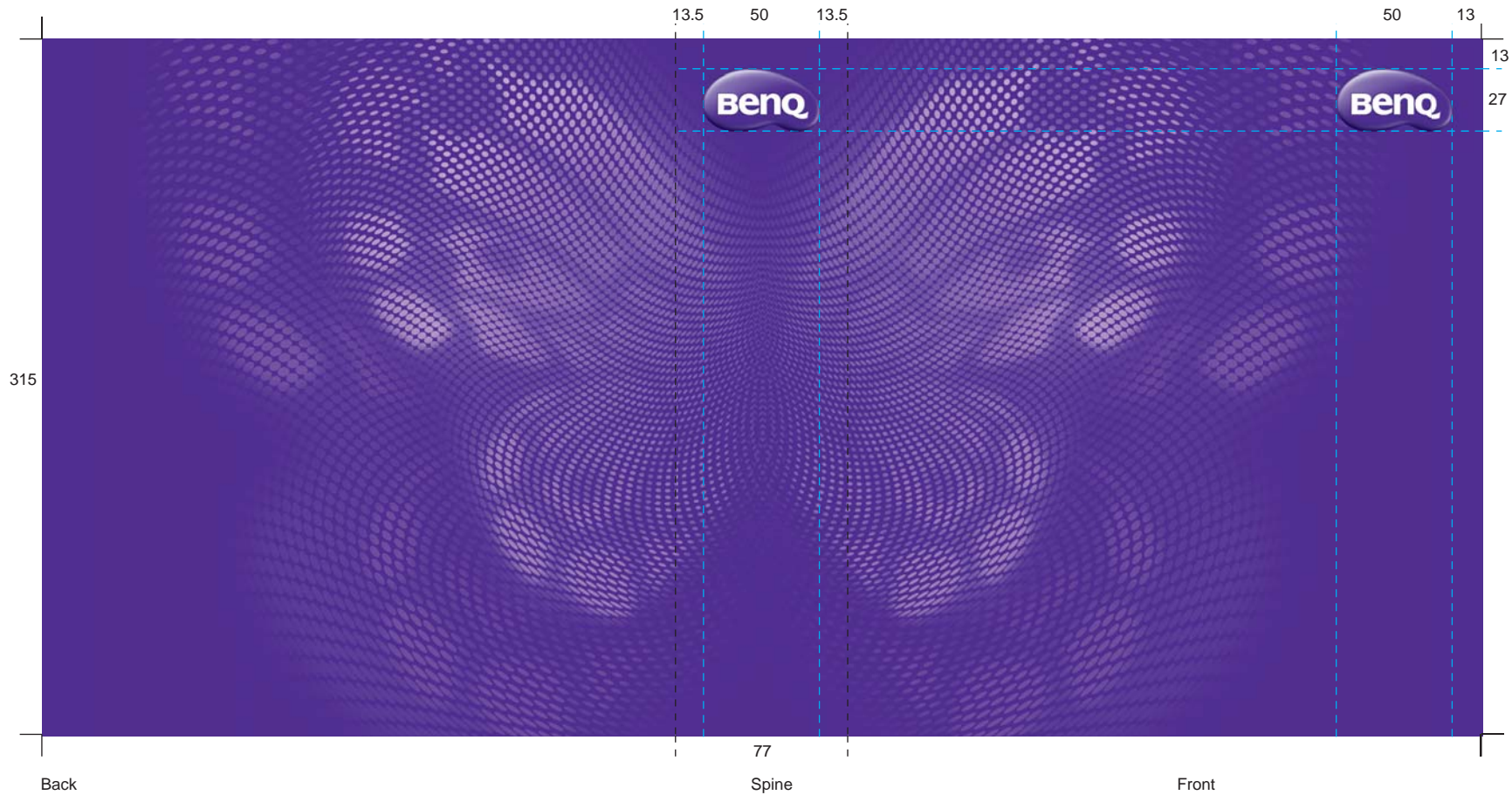



C 02.12 Stationery
Presentation Folder - Lever Arch or Ring Binder Continued





C 02.13 Stationery CD/DVD

Size

120mm x 120mm

Pattern

Use the Corporate Pattern and
Corporate Pattern Reversed .psd files.

There are two CD/DVD designs.

CD Design 1 - Purple

The pattern prints CMYK.

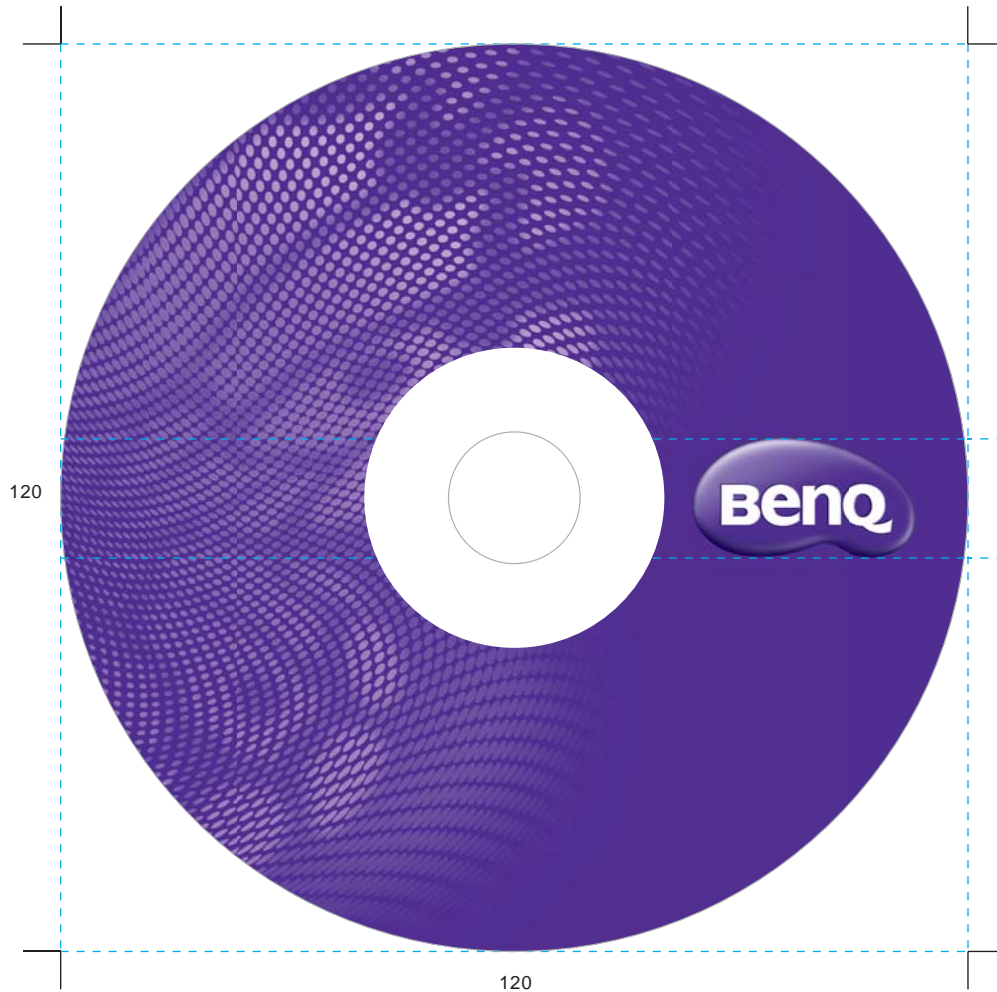

CD Design 2 - Reversed

The pattern prints CMYK and can be manually labeled.

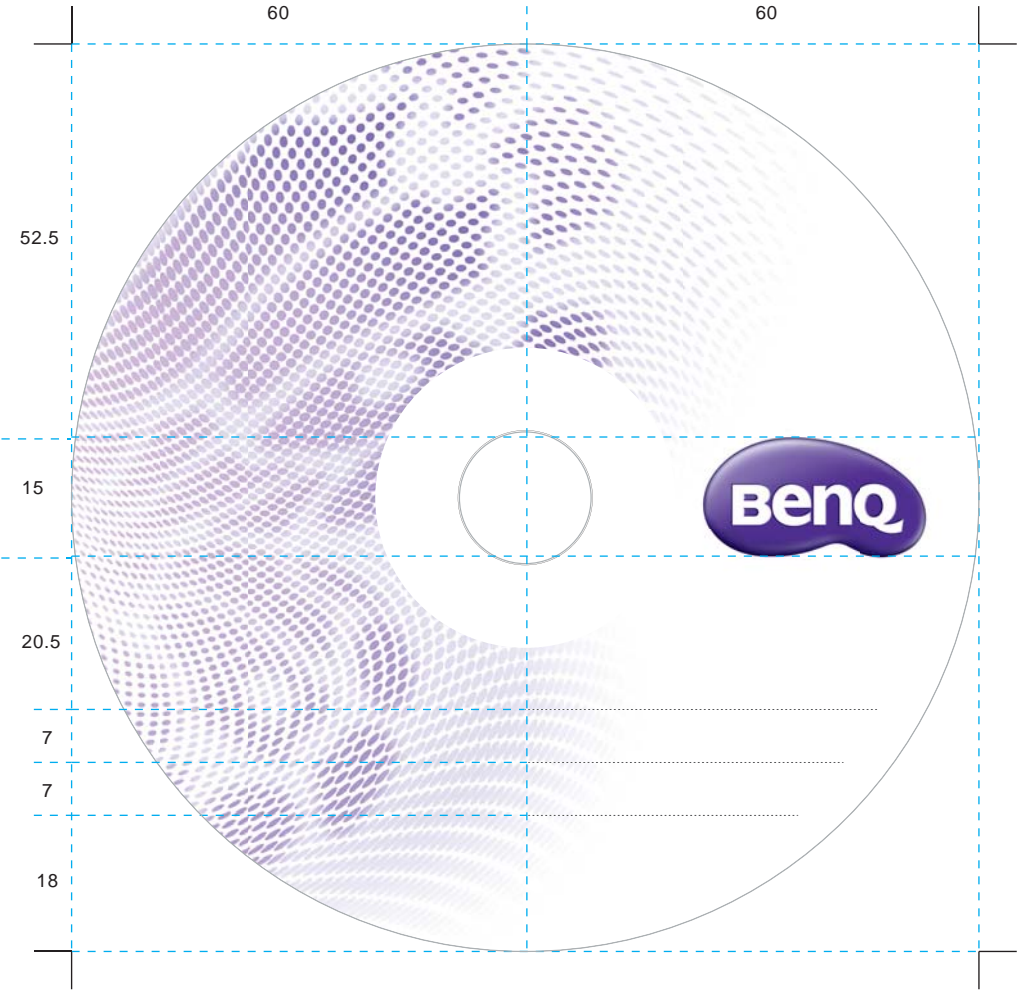



C 02.14 Stationery. CD/DVD Cover

Size

Finished Size 125mm x 142mm

Colour

The pattern and logo prints four colour process.
The inside is solid BenQ Purple PMS 268.

Pattern

Use the Corporate Pattern .psd file.

Disc Case Front Sleeve

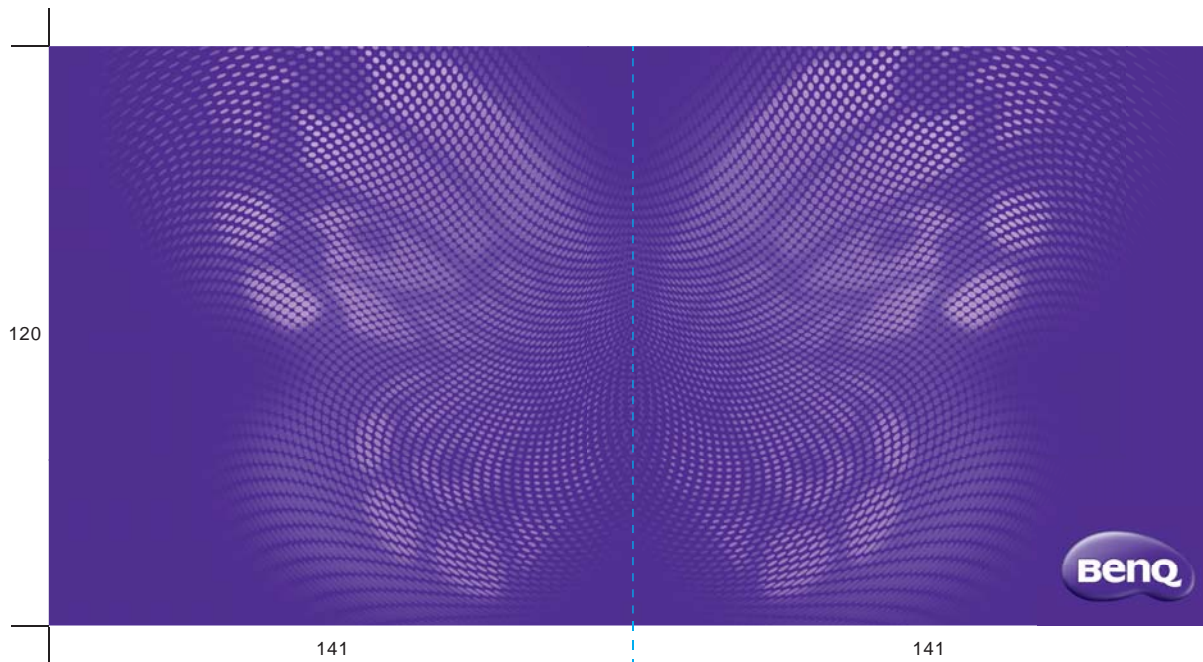

Disc Case Back Cover

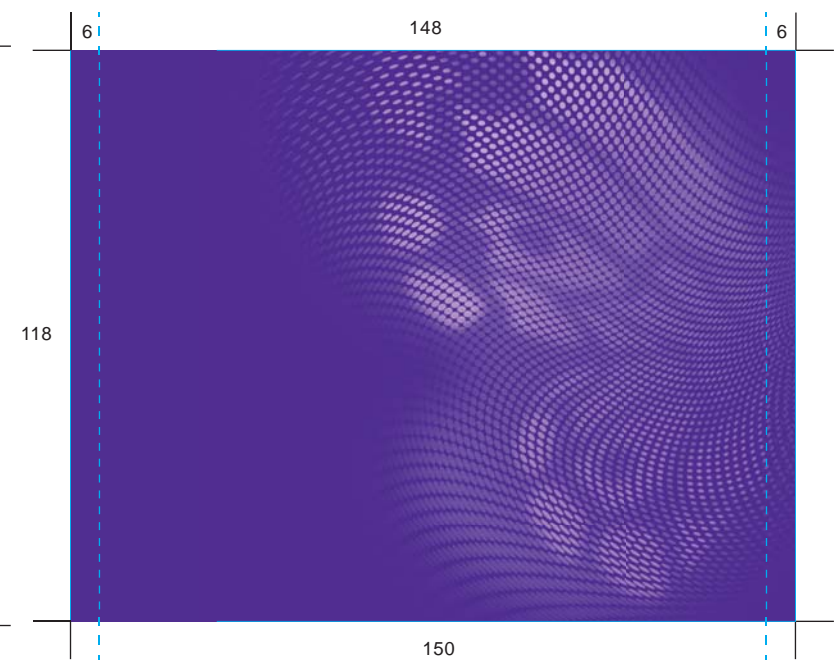



Corporate Identity and Visual Identity Guidelines
Section C 03
Business Forms



C 03.01 Business Forms Internal Form

Size

A4 297mm x 210mm

A5 148.5mm x 105mm

Alphabet Typography

Typeface Type size

Company Name

Gill Sans MT Light 13.5 Point

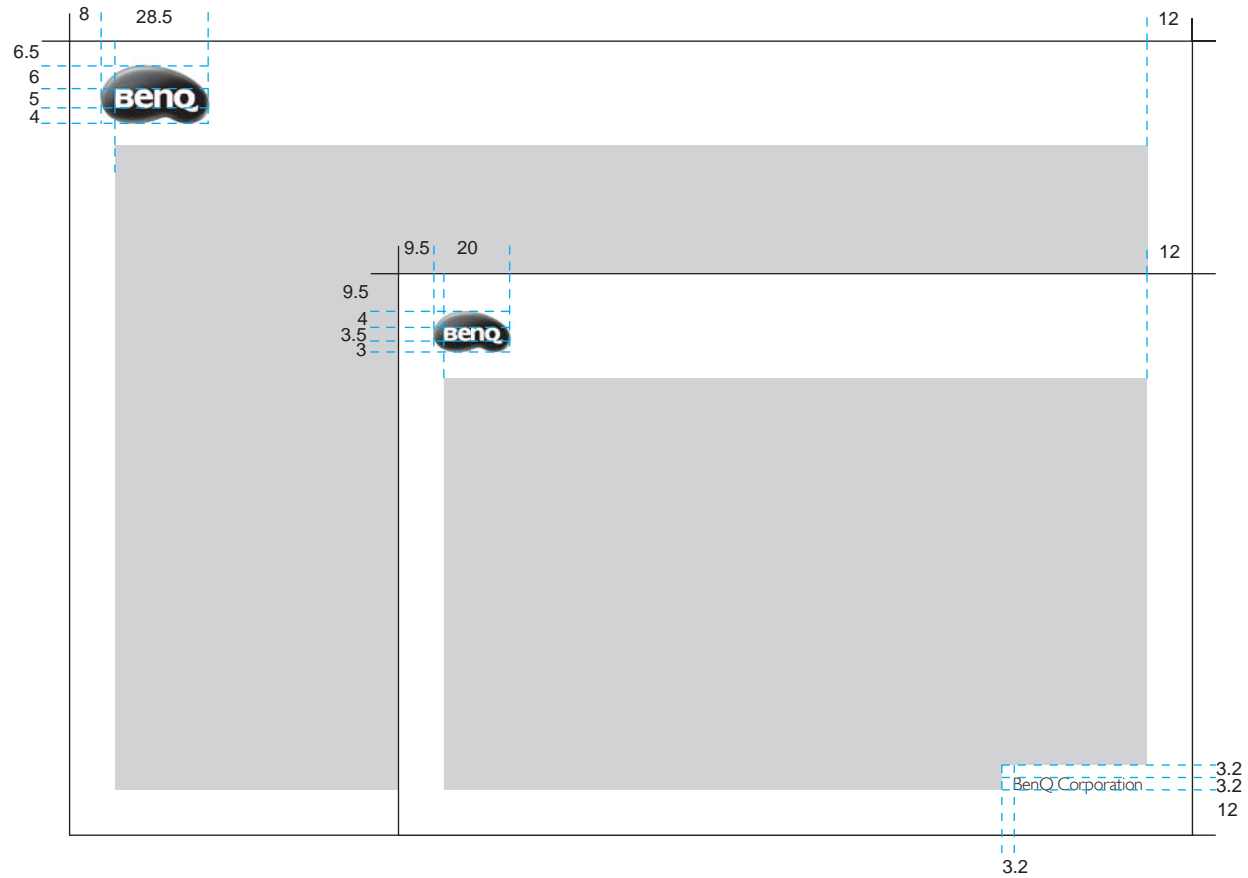

All measurements are in mm
Exhibits are 50% original size.



Black



Business form
positional area.
Do not print.



C 03.02 Business Forms Alphabet Standard

Size

A4 297mm x 210mm

A5 148.5mm x 105mm

Alphabet Typography

Typeface	Type size
Company Name	
Gill Sans MT Light	13.5 Point
Descriptor	
Gill Sans MT Light	23.5 Point

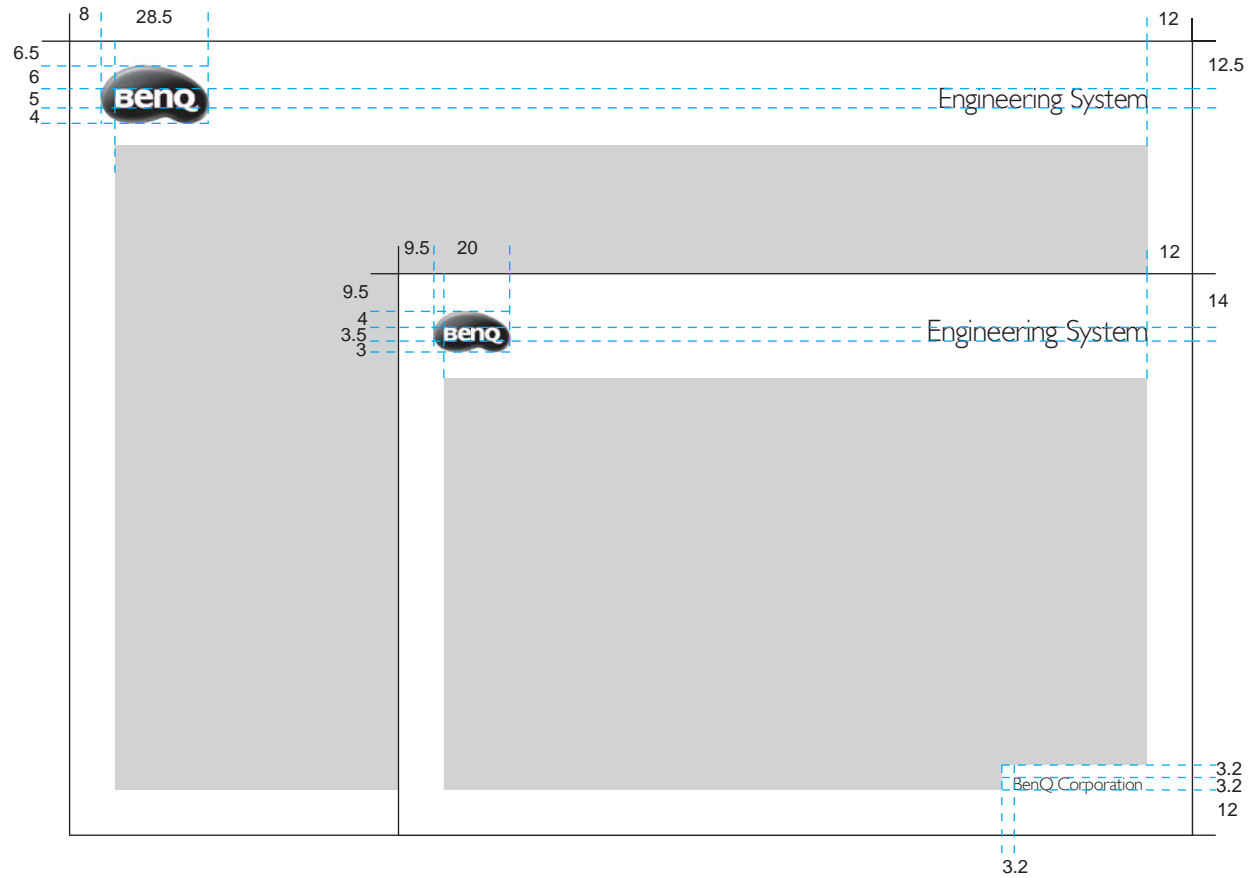

All measurements are in mm
Exhibits are 50% original size.



Black

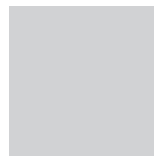

Business form
positional area.
Do not print.



C 03.03 Business Forms
Other Example

Gradient runs 220

		單據粘貼單																																																																		
<input type="checkbox"/> 沖借款 <input type="checkbox"/> 申請支票付款 <input type="checkbox"/> 零用金 <input type="checkbox"/> 電匯 粘貼單據共 張		年 月 日																																																																		
單 據 粘 貼 處	注意事項： 1. 發票、收據是否載明公司全銜、統一編號、日期、品名、單價、數量、稅額。大票金額是否正確，並班統一發票專用章(收據需蓋收據專用章及負責人章) 2. 發票憑證需附收執聯及拍抵聯，其他代用憑證(如收銀機發票)需影印一份作為拍抵聯 3. 單據粘貼單應請款方式，請屬部門	支出內容及成本歸屬明細																																																																		
	<table border="1" style="width: 100%; border-collapse: collapse;"> <thead> <tr> <th style="width: 20%;">歸屬部門</th> <th style="width: 30%;">摘要</th> <th style="width: 15%;">金額</th> <th style="width: 15%;">營業稅</th> <th style="width: 20%;">簽認*</th> </tr> </thead> <tbody> <tr><td> </td><td> </td><td> </td><td> </td><td> </td></tr> <tr><td> </td><td> </td><td> </td><td> </td><td> </td></tr> <tr><td> </td><td> </td><td> </td><td> </td><td> </td></tr> <tr><td> </td><td> </td><td> </td><td> </td><td> </td></tr> <tr><td> </td><td> </td><td> </td><td> </td><td> </td></tr> <tr><td> </td><td> </td><td> </td><td> </td><td> </td></tr> <tr><td> </td><td> </td><td> </td><td> </td><td> </td></tr> <tr><td> </td><td> </td><td> </td><td> </td><td> </td></tr> <tr><td> </td><td> </td><td> </td><td> </td><td> </td></tr> <tr><td> </td><td> </td><td> </td><td> </td><td> </td></tr> <tr> <td colspan="2" style="text-align: right;">小計</td> <td> </td> <td> </td> <td> </td> </tr> <tr> <td colspan="2" style="text-align: right;">合計</td> <td> </td> <td> </td> <td> </td> </tr> </tbody> </table>	歸屬部門	摘要	金額	營業稅	簽認*																																																			小計					合計						
歸屬部門	摘要	金額	營業稅	簽認*																																																																
小計																																																																				
合計																																																																				
合計 <input type="checkbox"/> 新台幣 <input type="checkbox"/> 其他：		仟 佰 拾 萬 仟 佰 拾 元整																																																																		
需款日期	受款人	廠商抬頭	付款到期日(依公司規定為三個月電匯)																																																																	
批示/會計	核決主管	部門主管	經辦人																																																																	
表單編號: PB-002		BenQ Corporation																																																																		



Black

All measurements are in mm
Exhibits are 50% original size.



C 03.05 ID Business Forms Employee ID Card

Size

55mm x 87mm

Alphabet Typography

Typeface **Type Size**

Company logo 5mm

Company Name
Microsoft JhengHei Regular 2.2mm

Text
Chinese Name
Microsoft JhengHei Bold 23pt

English Name
Gill Sans MT Regular 11pt

Employee ID
Gill Sans MT Regular 12pt

Colour

Top
BenQ Purple PMS 268

Middle
15% of BenQ Purple PMS 268

Bottom
0% of BenQ Purple PMS 268

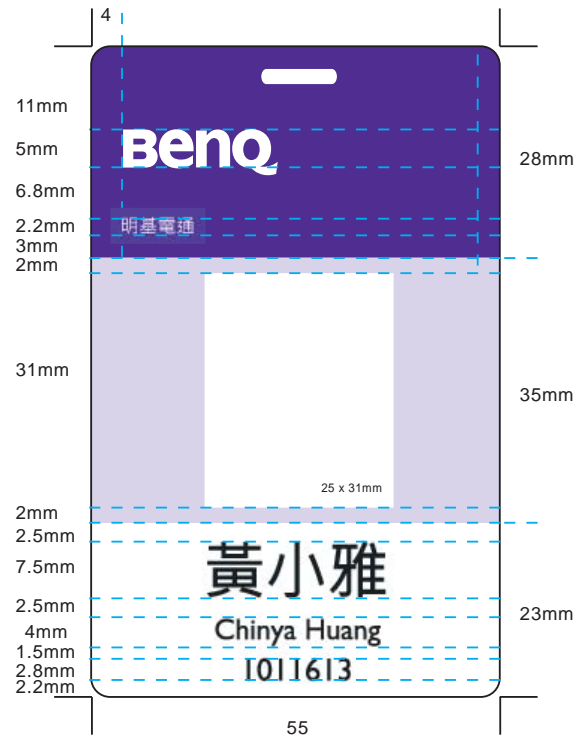

PMS 268



15% PMS 268



C 03.06 Business Forms Dealer Certificate

There are three levels of dealer certificates, golden, silver and copper dealers. The certificates are differentiated by the colour of the pattern and organic wave bar:

Size

A3 297mm x 420mm

Colour

The pattern prints four colour process. The type is either reversed white or matched to PMS Cool Gray 11.

Wave Bar Colour Breakdowns

Golden Dealer: PMS 268 or C86 M100Y0 K0

Silver Dealer: PMS 428 or C2 M0Y0 K18

Copper Dealer: 10% of PMS 268 or C9 M10Y0 K0

Pattern

Use the Corporate Pattern and Corporate Pattern Reversed .psd file.

Golden Dealer

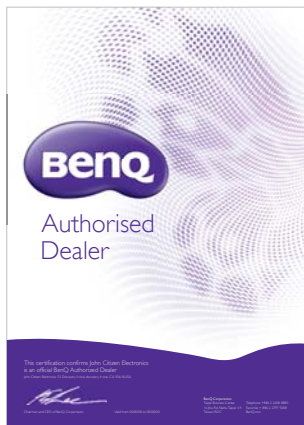

Silver Dealer

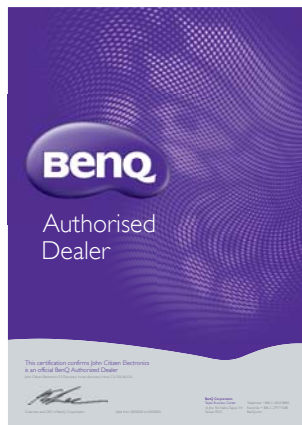

Copper Dealer



BenQ Logo authorized seal embossed silver foil.

Maximum height for certificate title block Do not resize BenQ logo and certificate title

77.5

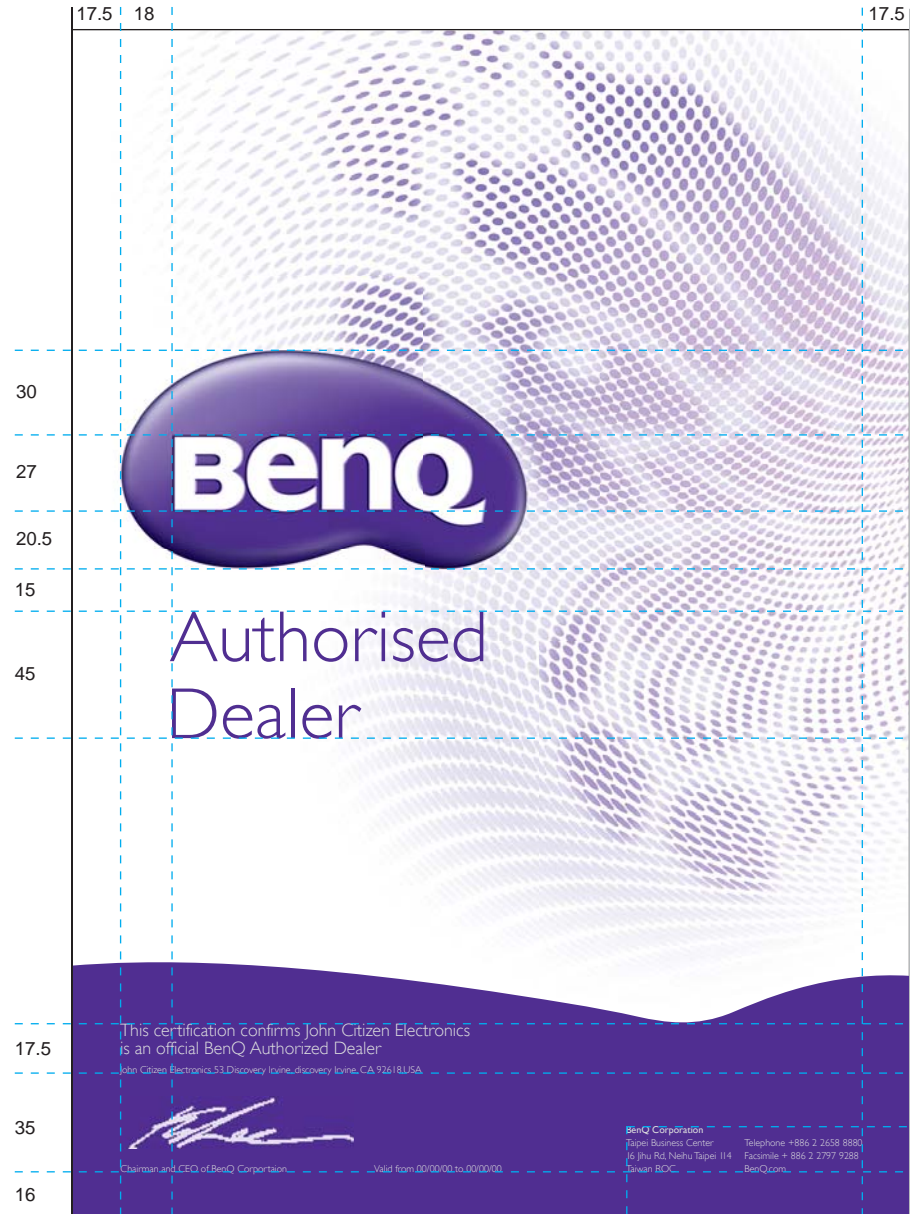



C 03.07 Business Forms School Certificate

Size

A3 297mm x 420mm

Alphabet Typography



Typeface	Type Size
BenQ School Certificate	
Gill Sans MT Light	62pt /70pt
Name of Certificate	
Gill Sans MT Light	32pt /48pt
Certificate Descriptor	
Gill Sans MT Light	22pt /25pt
Awardee Name	
Gill Sans MT Regular	50pt/84pt
BenQ President	
Gill Sans MT Light	22pt /25pt

Colour

The pattern prints four colour process.
The type is matched to PMS Cool Gray 11.

Pattern

Use the Corporate Pattern Reversed .psd file.

	148.5		148.5
53	BenQ School Certificate		
32	Top Development Program 2010		
70	It is to certify that		
80	Joselyn Liu		
	has completed all required courses of Top Development Program from March 2010 to January 2010.		
112			
5.5	President of BenQ School		
16			
26.5			
25			



C 03.08 Business Forms Award

Size

A3 297mm x 420mm

Alphabet Typography

Typeface	Type Size
BenQ School Certificate	
Gill Sans MT Light	62pt /70pt
Name of Certificate	
Gill Sans MT Light	32pt /48pt
Certificate Descriptor	
Gill Sans MT Light	22pt /25pt
Awardee Name	
Gill Sans MT Regular	50pt/84pt
BenQ President	
Gill Sans MT Light	22pt /25pt

Colour

The pattern prints four colour process.
The type is matched to PMS Cool Gray 11.

Pattern

Use the Corporate Pattern Reversed .psd file.

25 123.5 123.5 25

53

32

70

80

112

5.5

16

26.5

25

BenQ Award for Excellence

Lorem ipsum temque culles dolup

It is to certify that

Joselyn Liu

has been awarded for excellence
officit non repelendam eati resequi
am ut aut et quundae sit estiam

Joselyn Liu

President of BenQ School

BENQ BenQ School



C 03.09 Business Forms Advertising Launch Poster - Corporate Pattern

Size

A1 594mm x 841mm

Colour

The pattern prints four colour process.

Pattern

Use the Corporate Pattern .psd file.

Launch Poster option 1



Launch Poster option 2

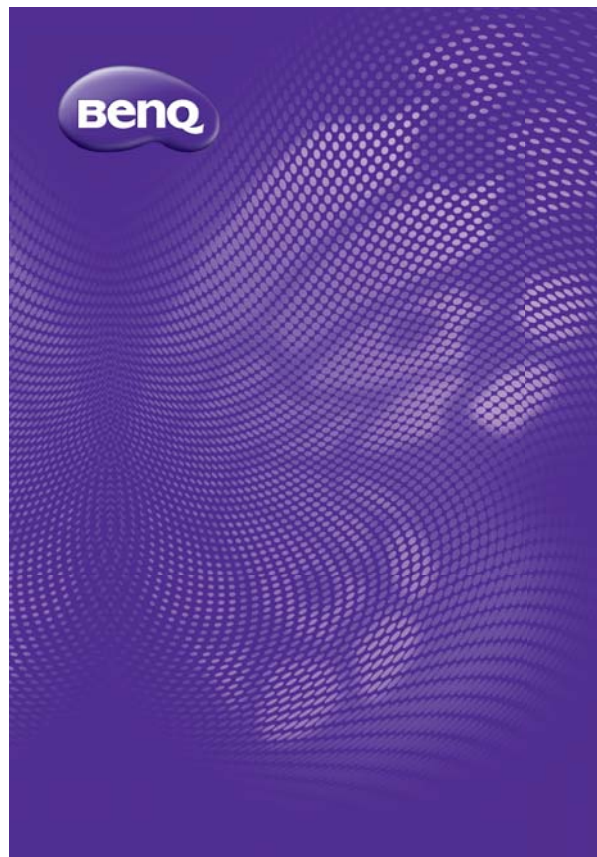

Launch Poster option 3





C 03.10 Business Forms Advertising Launch Poster - Corporate Pattern Reversed

Size

A1 594mm x 841mm

Colour

The pattern prints four colour process.

Pattern

Use the Reversed Corporate Pattern .psd file.

Launch Poster option 1



Launch Poster option 2

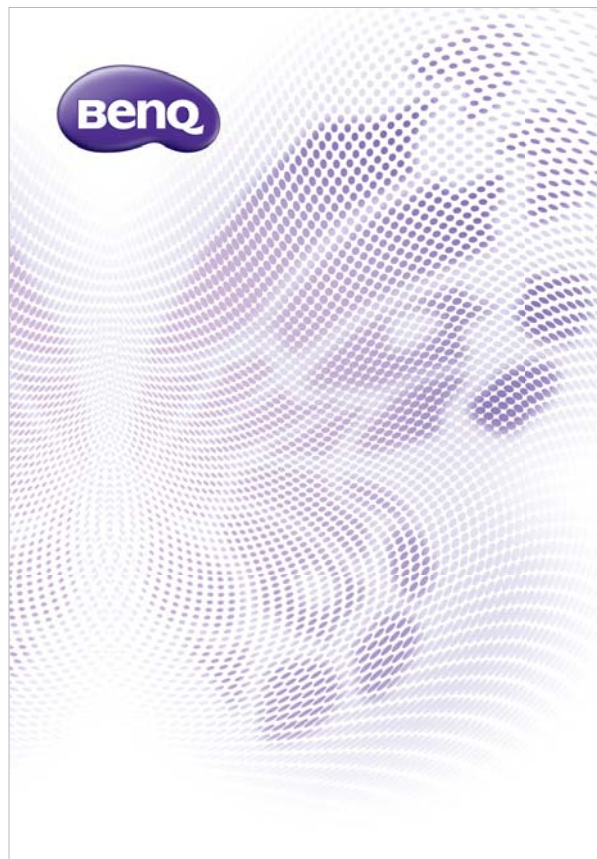

Launch Poster option 3





Corporate Identity and Visual Identity Guidelines
Section C 04
Corporate Signage



C 04.01 BenQ Corporate Signage Lobby Area Chinese

BenQ Purple PMS 268 Background Panel



Silver Background Panel



Lettering and Back Panel

Material

Hairline Stainless Steel
Anodised Aluminium or
Adhesive Vinyl Aluminium

Color

Silver PMS 877 or BenQ Purple
PMS 268 or White

Lighting

Indirect exterior lighting fixtures
(if required)

White Panel Background





C 04.02 BenQ Corporate Signage Lobby Area Alphabet

BenQ Purple PMS 268 Background Panel



Silver Background Panel



Lettering and Back Panel

Material

Hairline Stainless Steel
Anodised Aluminium or
Adhesive Vinyl Aluminium

Color

Silver PMS 877 or BenQ Purple
PMS 268 or White

Lighting

Indirect exterior lighting fixtures
(if required)

White Panel Background





C 04.03 BenQ Corporate Signage External Neon Sign





C 04.04 BenQ Corporate Signage External Sign

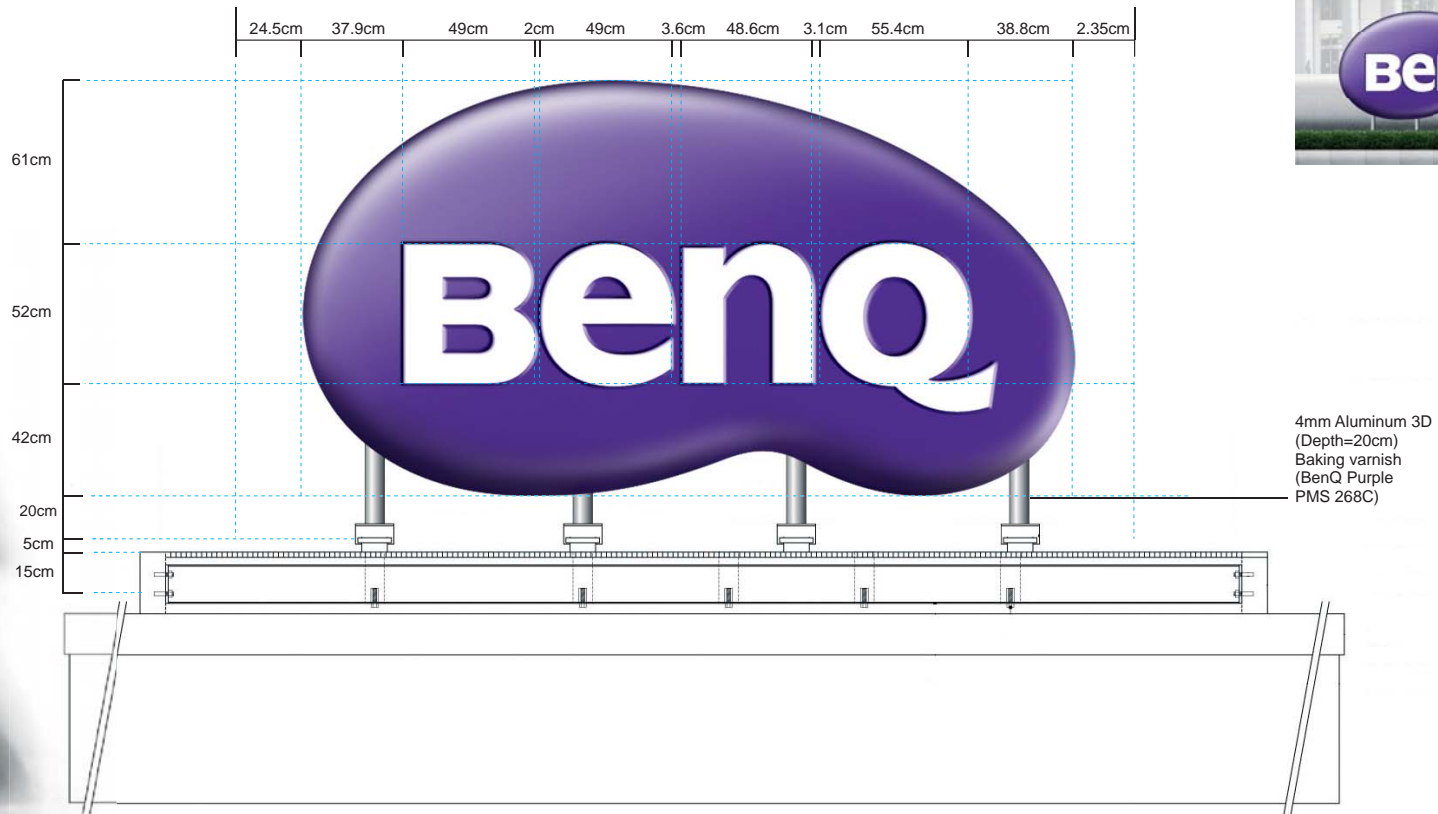



C 04.06 BenQ Corporate Signage External Sign

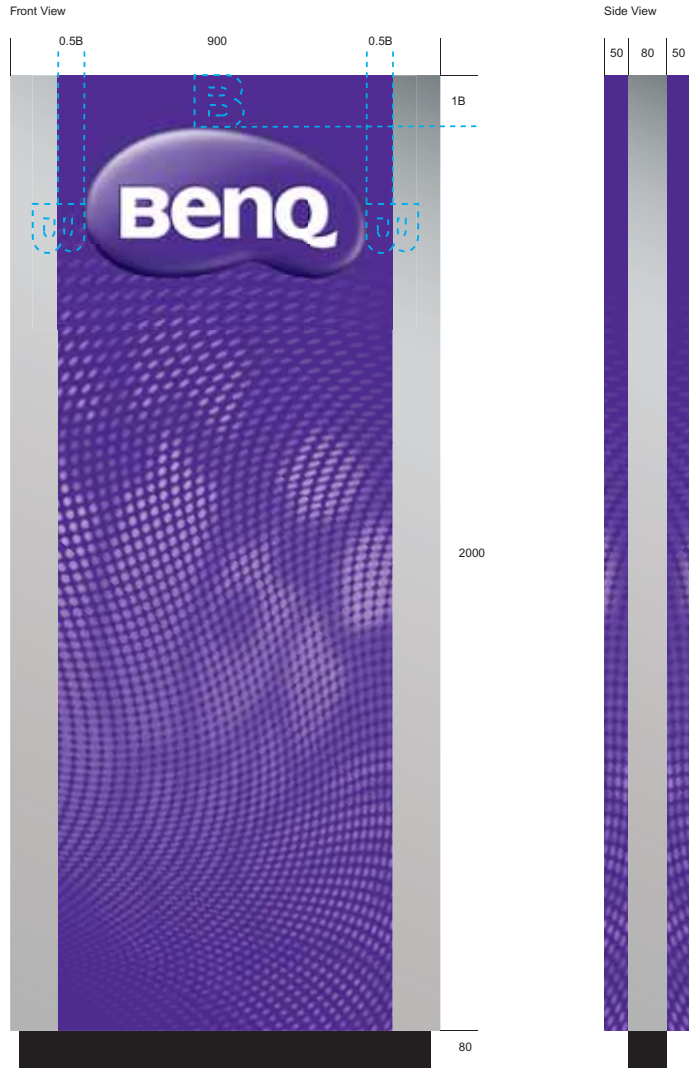

This signage is designed to welcome visitors to BenQ buildings.

Design Option One



Design Option Two



All measurements are approximate



C 04.07 BenQ Corporate Signage Application Examples - Banners - Option 1

For banners that are over 2 metres in height the BenQ Logo should sit at the base of the banner with the company name at the top.

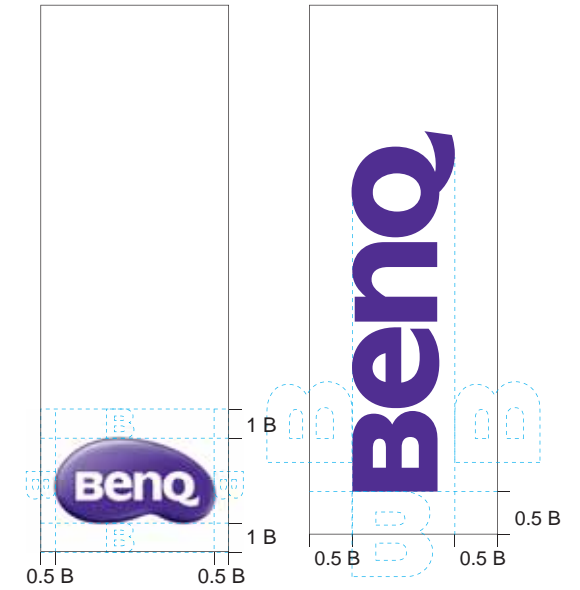



C 04.08 BenQ Corporate Signage Application Examples - Banners - Option 2

Hand held banners

For banners that are to be held by people the BenQ Logo should sit at the top of the banner with the company name at the bottom.

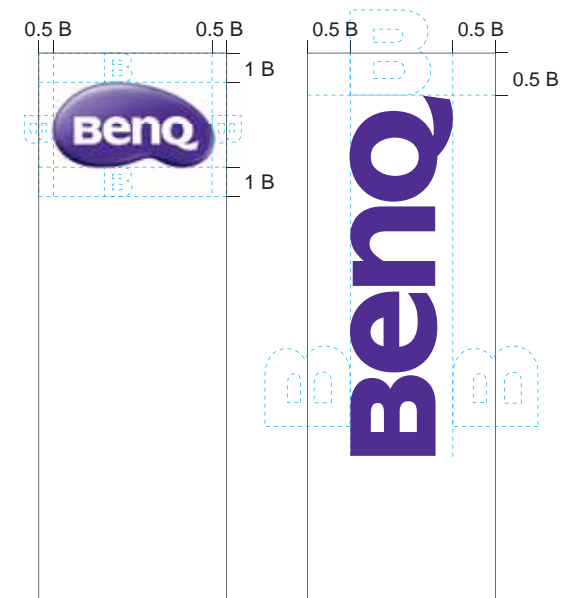



C 04.09 BenQ Corporate Signage
Application Examples - Banners - Option 3

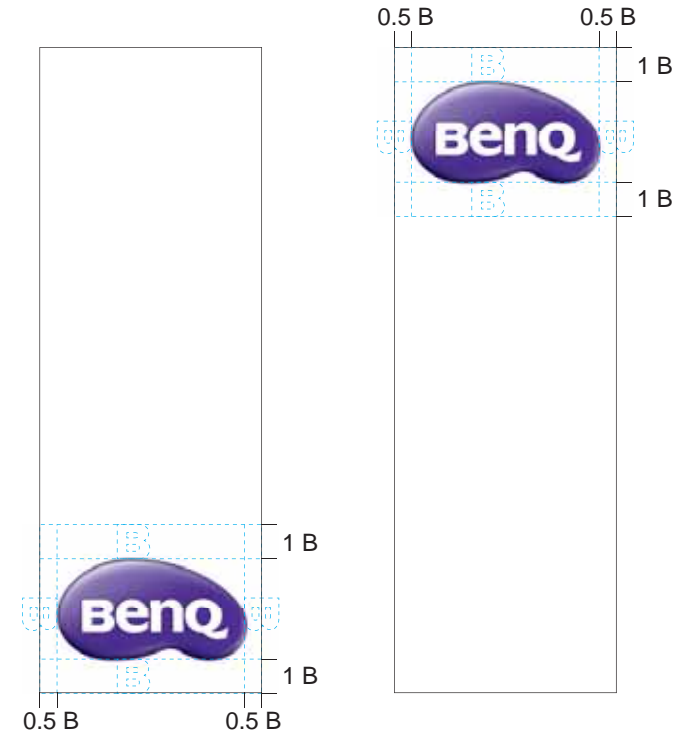
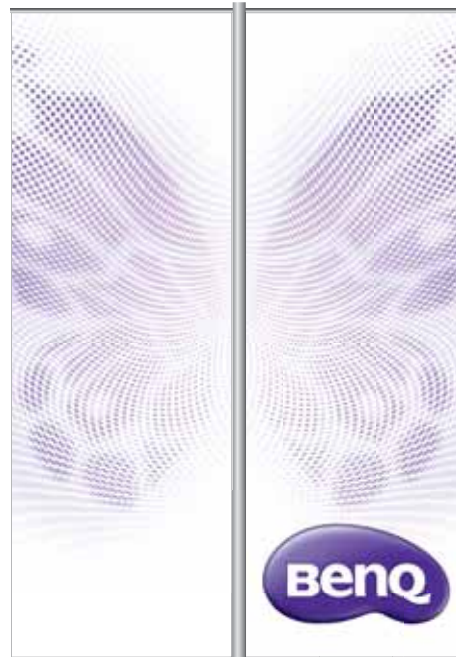



C 04.10 BenQ Corporate Signage
Application Examples - Corporate Flags





C 04.11 BenQ Corporate Signage
Application Examples - Company Flags

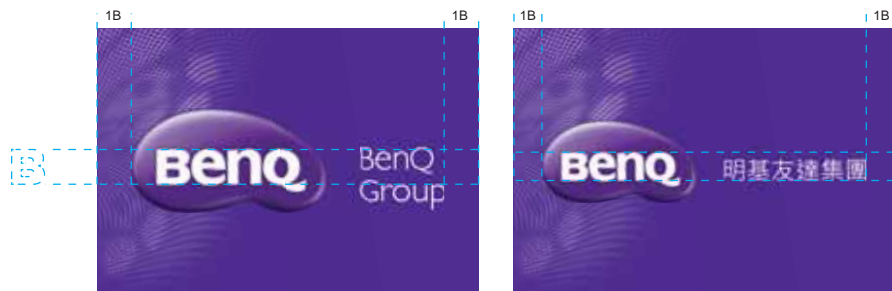



C 04.12 BenQ Corporate Signage Vehicle Livery

Colour

The vehicle is Silver or White. The BenQ Logo and the URL type is BenQ Purple PMS 268.

Size and Positioning

The BenQ Logo is positioned on the back doors. The decal on the back window is transparent. Use two way adhesive vinyl to allow vision through the window. The URL aligns with the base of the type in the BenQ Logo. Exact size and positioning of graphics can only be obtained by sighting and measuring the actual vehicle, as models vary in detail, including badge placement and other features such as door bumpers and handles. All these elements must be considered when applying the graphics. Graphics appear on both sides of the vehicle.

Type

The typeface for secondary information is Gill Sans MT Light.





C 04.13 BenQ Corporate Signage Application Examples Repeat Logo for Media/Press Backdrop

This example demonstrates how the BenQ Logo may be used as a repeat pattern for media backdrops and press conferences. There are two design options.

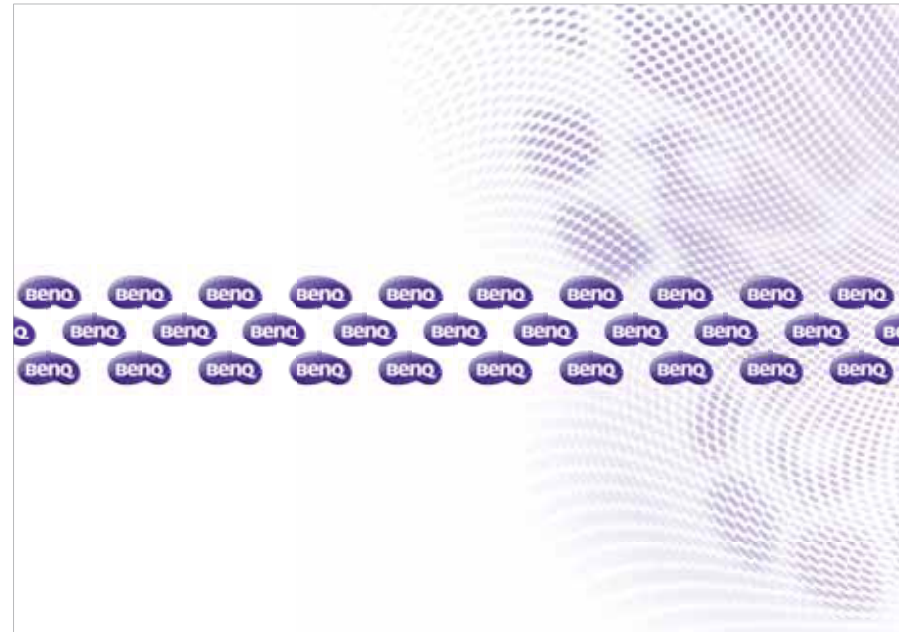



C 04.14 BenQ Corporate Signage Lectern

The lectern is made from curved MDF (wooden material). The MDF is laminated with a gloss aluminium sheet. The Corporate Pattern is a digital transparent adhesive sticker applied to the gloss aluminium sheet.

The inside of the base has an iron board for weight balance.

The BenQ Logo is 10mm thick acrylic BenQ Purple.

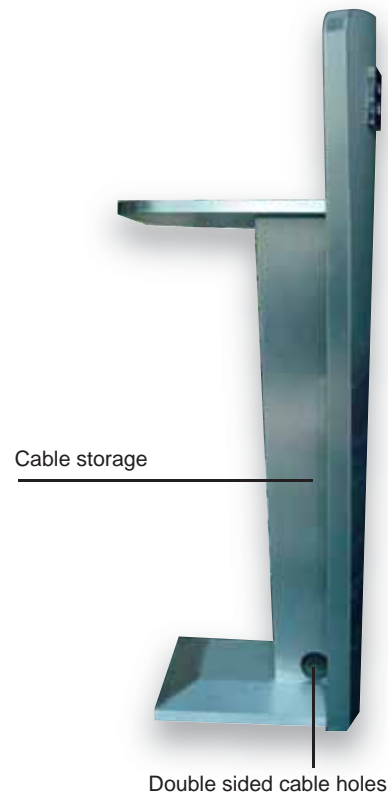

Round curve for the edges





C 04.15 BenQ Corporate Signage Lectern Continued

Pattern

The lectern can feature either the Corporate Pattern or the Reversed Corporate Pattern.

Cropping Guides



Design Option One

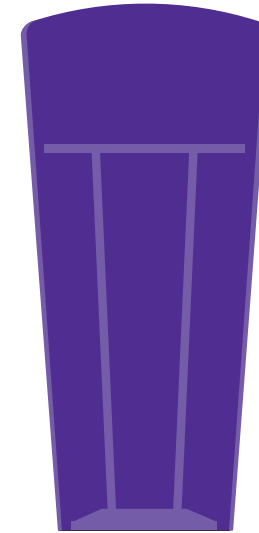
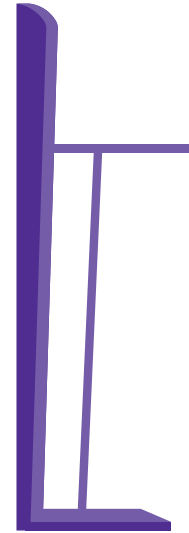
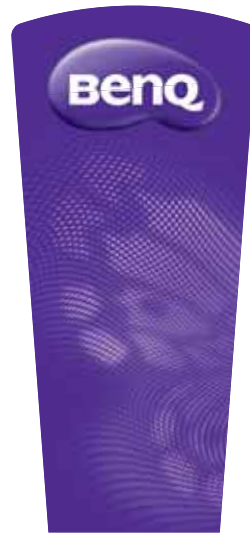

Design Option Two





C 04.16 BenQ Corporate Signage Lectern Specifications

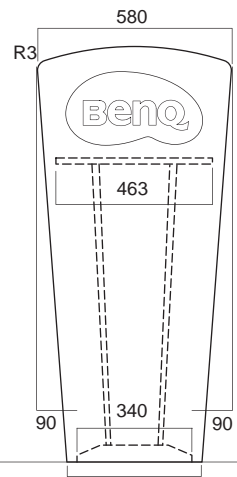
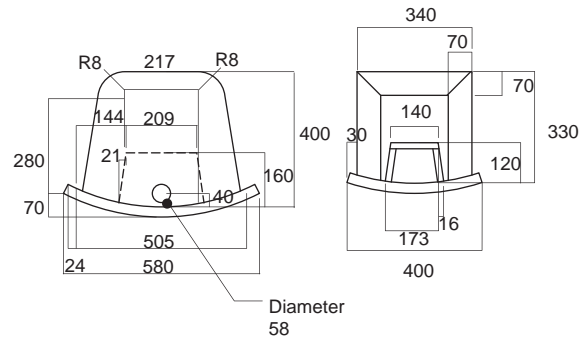

Front View

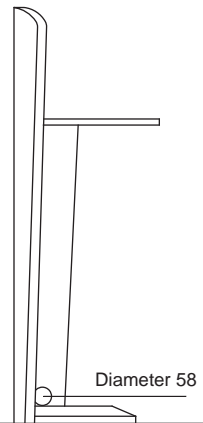

Side View

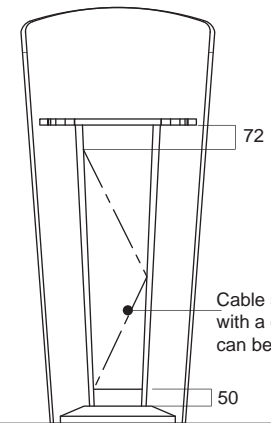

Back View

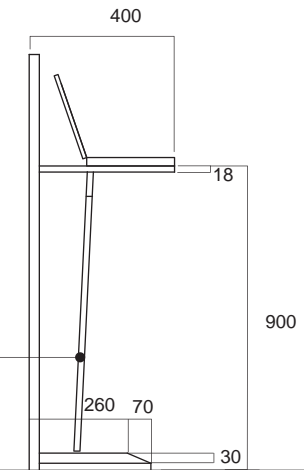

Section View

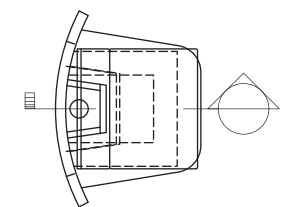
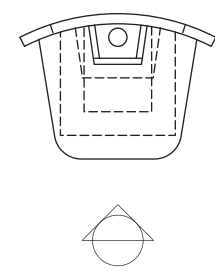
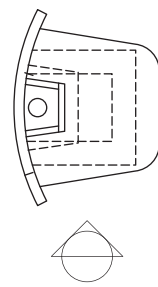
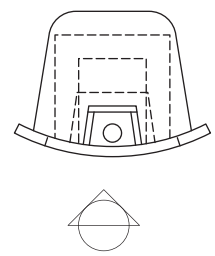



Corporate Identity and Visual Identity Guidelines
Section C 05
ID Materials



C 05.01 ID Materials Generic Branding Badge

The branding badge is used for a range of applications including:
Internal office branding tools
T-shirts and Corporate gift labels.





C 05.02 ID Materials Multi-Purpose Employee Name Badge

The multi-purpose name badge is for one-off demonstration or workshop identification. The badge can be produced with and without a workshop logo and name.

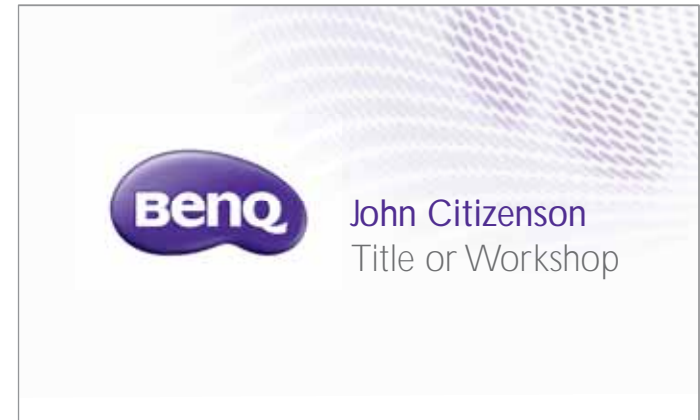
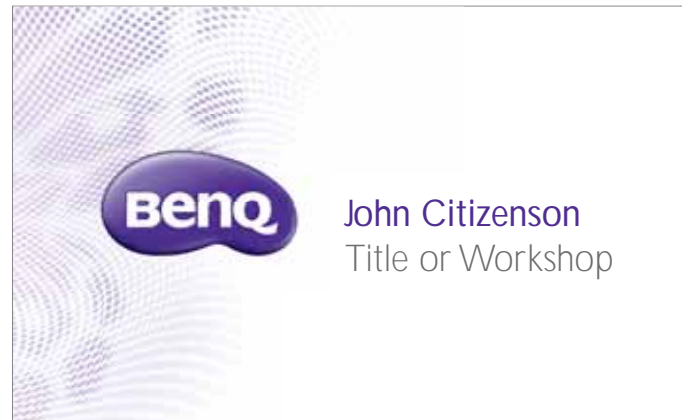



Corporate Identity and Visual Identity Guidelines
Section C 06
Promotional Items



C 06.01 Promotional Items Paper Cup

Size

70mm x 80mm

Colour

The BenQ Logo and pattern prints 4 colour process.

Pattern

Use the Reversed Corporate Pattern .psd file.

Cropping Guide

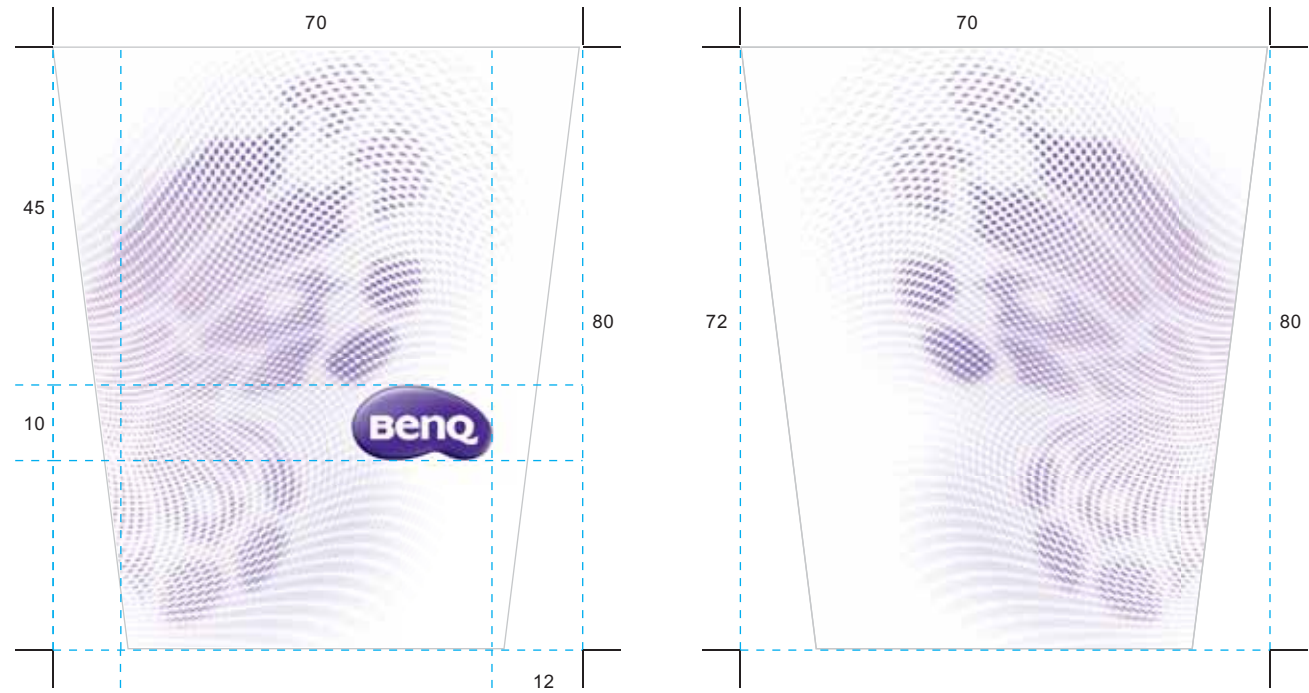
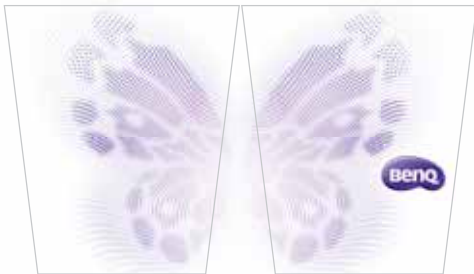



C 06.02 Promotional Items Plastic Bag

Colour

The BenQ Logo and pattern prints
four colour process over the entire bag.

Size

260mm x 320mm
To suit A4 documents.

Pattern

Use the Corporate Pattern .psd file.
Repeat the pattern on both sides.
Refer to the cropping examples below.

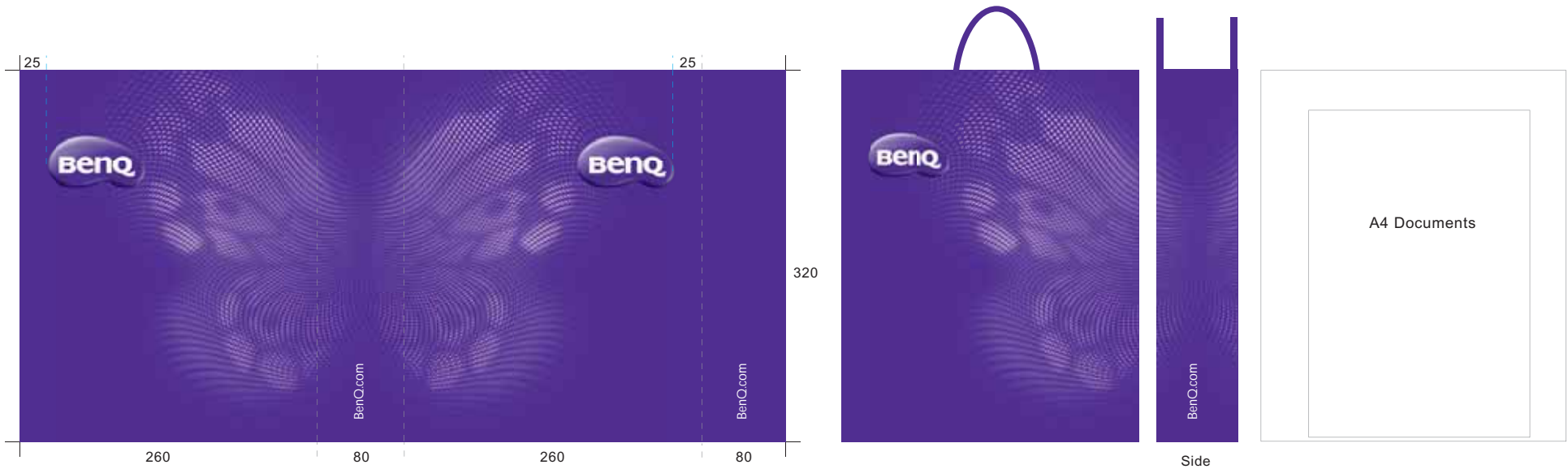

Design Option 1



Design Option 2



Design Option 3



Design Option 4



The BenQ URL can
be replaced on the
side of the bag by
a company name



C 06.03 Promotional Items Plastic Bag - Reversed Pattern

Colour

The BenQ Logo and pattern prints
four colour process over the entire bag.

Size

260mm x 320mm
To suit A4 documents.

Pattern

Use the Corporate Pattern Reversed .psd
file. Repeat the pattern on both sides.
Refer to the cropping examples below.

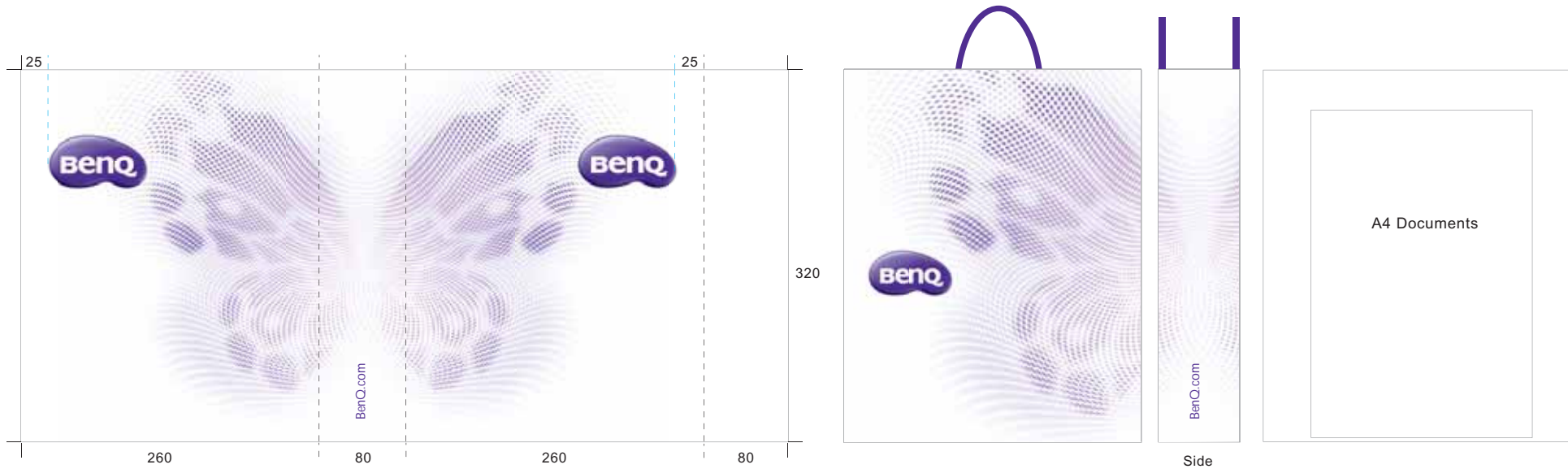

Design Option 1



Design Option 2



Design Option 3



Design Option 4



The BenQ URL can
be replaced on the
side of the bag by
a company name



C 06.04 Promotional Items Paper Bag

Colour

The BenQ Logo and pattern prints
four colour process over the entire bag.

Size

350mm x 450mm x 120mm
To suit A3 documents and products.

Pattern

Use the Extended Corporate Pattern .psd file.
Repeat the pattern on both sides.
Refer to the cropping examples below.

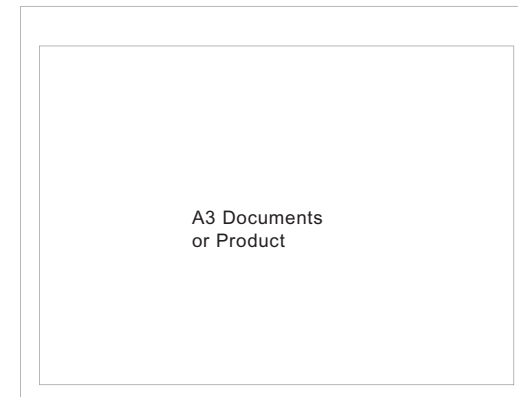
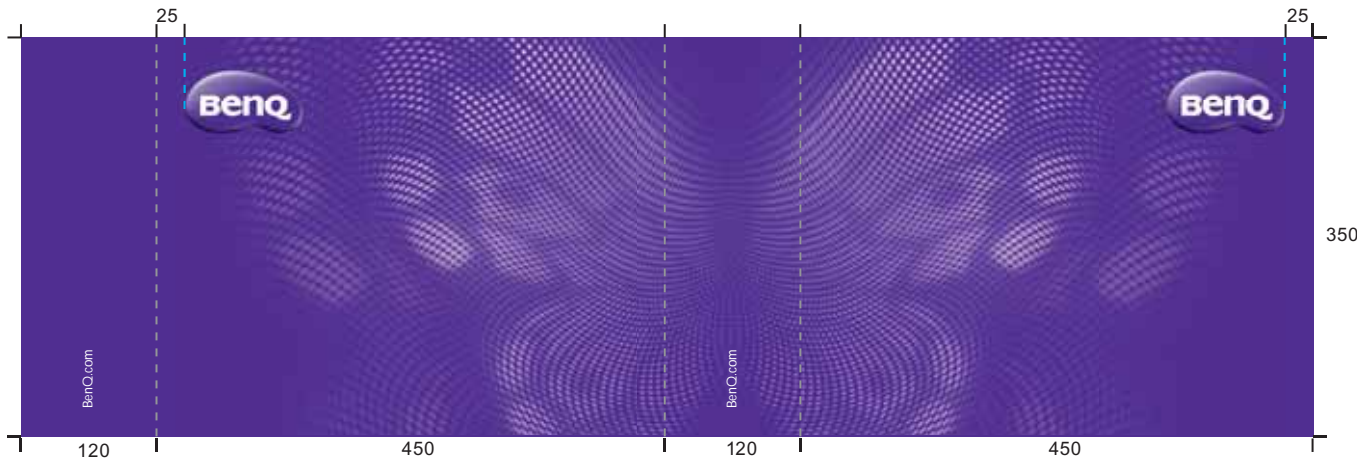

Design Option 1



Design Option 2

The BenQ URL can
be replaced on the
side of the bag by
a company name



C 06.05 Promotional Items Paper Bag - Reversed Pattern

Colour

The BenQ Logo and pattern prints
four colour process over the entire bag.

Size

350mm x 450mm x 120mm
To suit A3 documents and products.

Pattern

Use the Extended Corporate Pattern Reversed .psd
file. Repeat the pattern on both sides.
Refer to the cropping examples below.

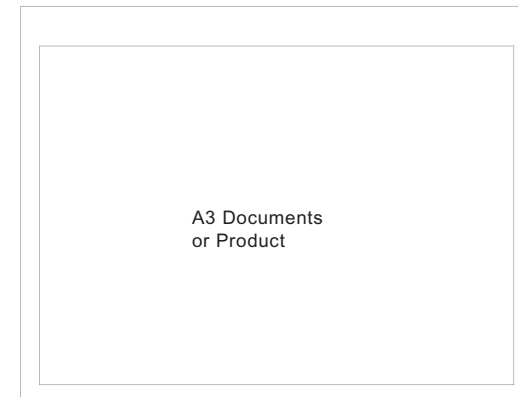
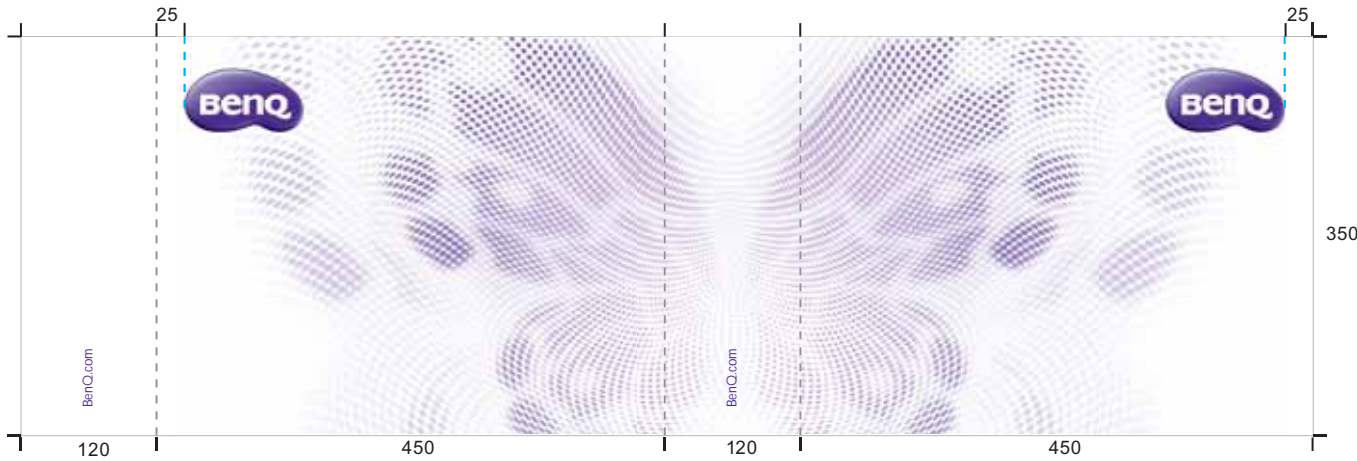

Design Option 1



Design Option 2

The BenQ URL can
be replaced on the
side of the bag by
a company name



C 06.06 Promotional Items Paper Bag Environmentally Friendly

Colour

The BenQ Logo and pattern print single colour PMS 268.

Size

350mm x 450mm x 120mm
To suit A3 documents and products.

Pattern

Use the Extended Corporate Reversed .psd file.
Repeat the pattern on both sides.
Refer to the cropping guide below.

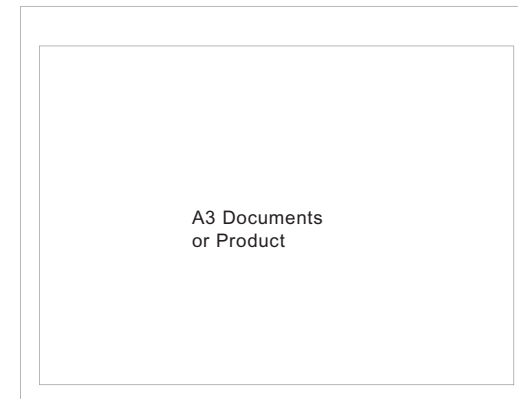
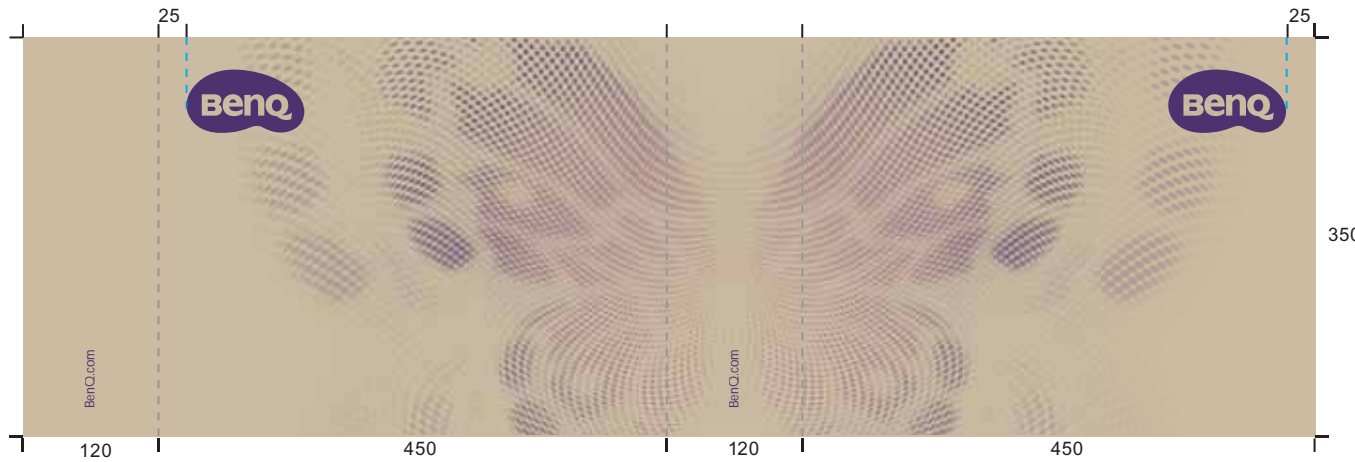

Design Option 1



Design Option 2

The BenQ URL can be replaced on the side of the bag by a company name



C 06.07 Promotional Items Uniforms. Polo Shirt



Polo shirt is White with a Purple branding badge.

Branding badge may be embroidered or printed on the front.



Polo shirt is BenQ Purple with a White branding badge.

Branding badge may be embroidered or printed on the front.

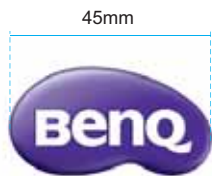

Logo should be 45mm wide



C 06.08 Promotional Items Cycling Jersey



Polo shirt is White with a Purple branding badge.

Branding badge may be embroidered or printed on the front.



Polo shirt is BenQ Purple with a White branding badge.

Branding badge may be embroidered or printed on the front.

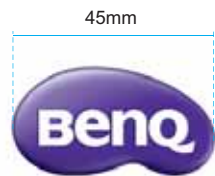

Logo should be 45mm wide



C 06.09 Promotional Items Mug and Note Book

This example demonstrates how the BenQ Logo and the Corporate Pattern may be used on promotion items for staff, customers and clients. Use either the BenQ Corporate or Reverse Corporate Pattern on these items.

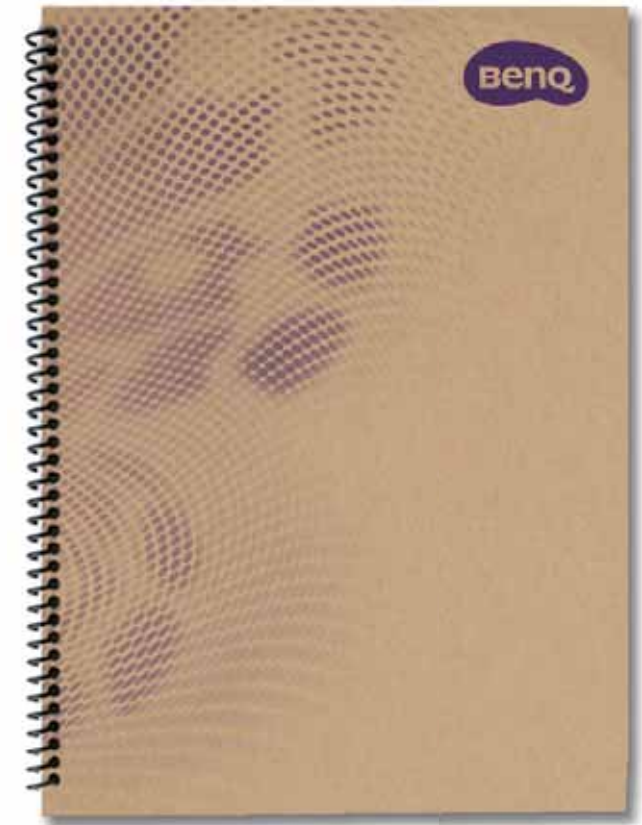



Corporate Identity and Visual Identity Guidelines
Section C 07
Electronic Items



C 07.01 Electronic Items PowerPoint Template - Corporate

Size

254mm x 109.5mm or 254 x 143mm (16:9)

Alphabet Typography

Typeface	Type Size
Presentation Title	
Gill Sans MT Regular	36pt
Subtitle	
Gill Sans MT Regular	24pt
Presenter's Name	
Gill Sans MT Regular	20pt
Document Details	
Gill Sans MT Regular	16pt

Title Page



End Page

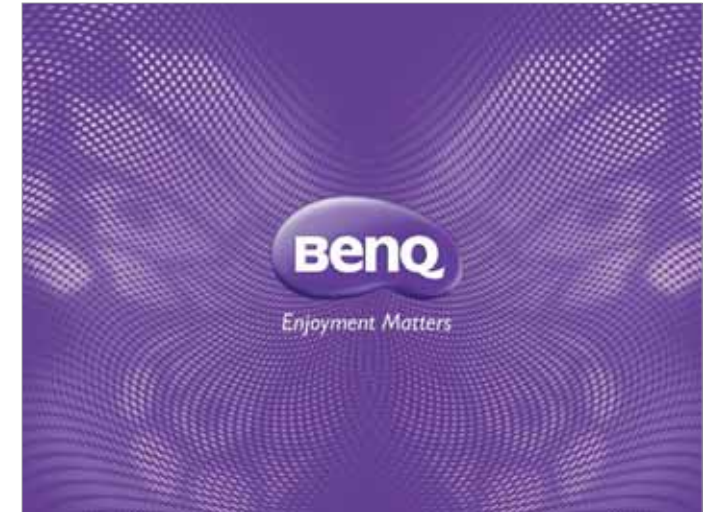

Title Page 16:9



End Page 16:9

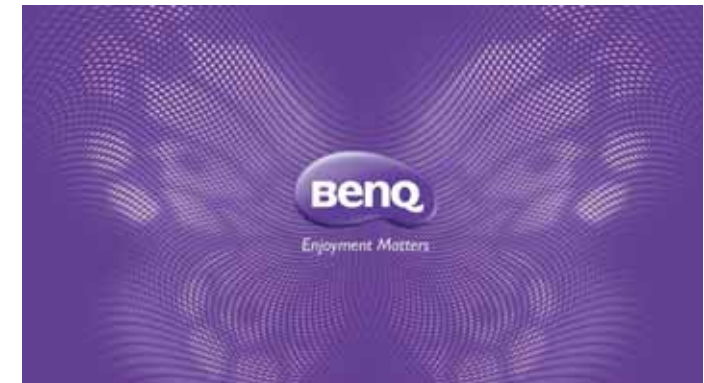



C 07.02 Electronic Items PowerPoint Template - Corporate Text Pages

Size

254mm x 109.5mm or 254 x 143mm (16:9)

Alphabet Typography

Typeface	Type Size
Headings	
Gill Sans MT Regular	36pt
Text First Line	
Gill Sans MT Regular	24pt
Text Second Line	
Gill Sans MT Regular	20pt

New Section Purple



New Section Purple Reversed



Text Page Purple



Text Page Purple Reversed





C 07.03 Electronic Items Email Signature

Alphabet Typography

Typeface Small Type Sizes

Name	
Gill Sans MT Regular	9pt /11pt
Address and Contact Details	
Gill Sans MT Regular	8pt /10pt
Confidentiality Notice	
Gill Sans MT Regular	7pt /9pt

Typeface Medium Type Sizes

Name	
Gill Sans MT Regular	10pt /12pt
Address and Contact Details	
Gill Sans MT Regular	9pt /11pt
Confidentiality Notice	
Gill Sans MT Regular	8pt /10pt

Typeface Large Type Sizes

Name	
Gill Sans MT Regular	11pt /13pt
Address and Contact Details	
Gill Sans MT Regular	10pt /11pt
Confidentiality Notice	
Gill Sans MT Regular	9pt /10pt

Carol Hsueh
Branding Dept.
Brand Management Centre

BenQ Corporation
16 Jihu Road, Neihu, Taipei 114, Taiwan
Telephone +886-2-2658-8880 Ext 7701
Facsimile +886-2-6602-6677
Carol.Hsueh@BenQ.com
BenQ.com



----- Confidentiality Notice -----

The opinions and views expressed in this e-mail are solely those of the author and do not necessarily represent our company and its affiliates. If this e-mail is not originally intended for you, or received by you in error, do not disclose its content to anyone and delete it immediately. This e-mail may contain information that is legally privileged, confidential or exempt from disclosure.

100% Small Type Sizes



C 07.04 Electronic Items Internal Form - Engineering

Size

A4 297mm x 210mm

Typeface

Heading

Gill Sans MT Regular

Text

Gill Sans MT Regular

Small Type Sizes

16pt

12pt

Vertical Format

The vertical format template shows a header with the BenQ logo on the left and 'Engineering System' on the right. Below the header, the text 'Heading Font Face: Gill Sans MT, 16 point' and 'Text Font Face: Gill Sans MT, 12 point' is displayed.

Horizontal Format

The horizontal format template shows a header with the BenQ logo on the left and 'Engineering System' on the right. Below the header, the text 'Heading Font Face: Gill Sans MT, 16 point' and 'Text Font Face: Gill Sans MT, 12 point' is displayed.



C 07.05 Electronic Items Internal Form - HR

Size

A4 297mm x 210mm

Typeface

Heading

Gill Sans MT Regular

Text

Gill Sans MT Regular

Small Type Sizes

16pt

12pt

Vertical Format

The vertical format form layout features a header with the BenQ logo on the left and the text "Engineering System" on the right. Below the header, the heading font is specified as Gill Sans MT, 16 point, and the text font is specified as Gill Sans MT, 12 point.

Horizontal Format

The horizontal format form layout features a header with the BenQ logo on the left and the text "Engineering System" on the right. Below the header, the heading font is specified as Gill Sans MT, 16 point, and the text font is specified as Gill Sans MT, 12 point.



C 07.06 Electronic Items Electronic Fax Template

Size

A4 297mm x 210mm

File Type

Microsoft Word .doc

English Fax Template



Fax Transmittal

Fax: "[Click here and type fax number]"
To: "[Click here and type name]"
From: "[Click here and type name]"
Re: "[Click here and type subject of fax]"
Cc: "[Click here and type name]"
Date: May 3, 2011
Pages: Page 1 of [Click here and type # of pages]

BenQ Corporation
16 Jihu Road, Neihu,
Taipei 114, Taiwan
Tel: +886-2-2658-8880
Fax: +886-2-2797-9288
BenQ.com

Chinese Fax Template



Fax Transmittal

Fax: "[Click here and type fax number]"
To: "[Click here and type name]"
From: "[Click here and type name]"
Re: "[Click here and type subject of fax]"
Cc: "[Click here and type name]"
Date: May 3, 2011
Pages: Page 1 of [Click here and type # of pages]

明基電通股份有限公司
台北市 114
內湖區基湖路 16 號
電話: (02) 2727-8899
傳真: (02) 2797-9288
BenQ.com



C 07.07 Electronic Items Letterhead Template

Size

A4 297mm x 210mm

File Type

Microsoft Word .doc

English Letterhead Template

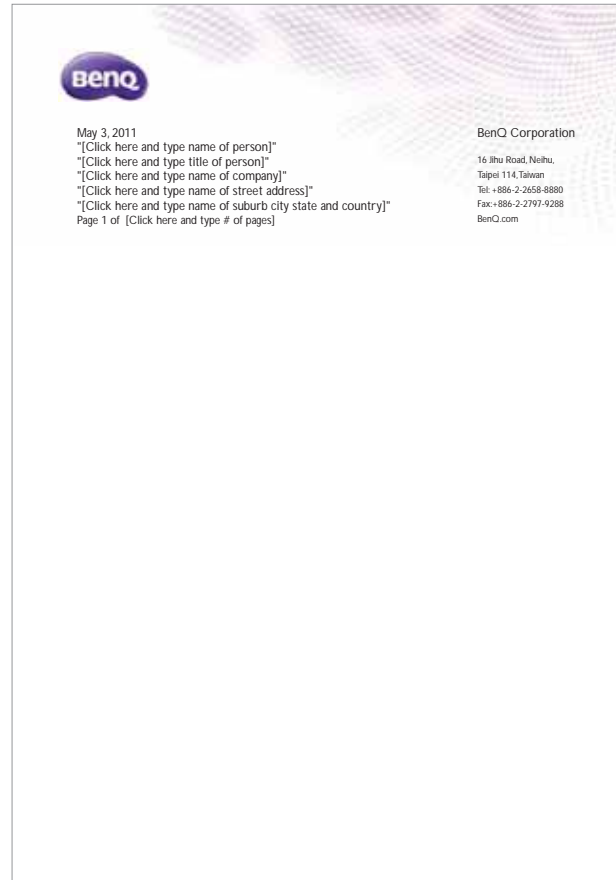

The English Letterhead Template features a decorative background with a grid of dots in shades of purple and blue. In the top left corner, there is a BenQ logo. The text is arranged in two columns. The left column contains the date 'May 3, 2011' followed by four lines of placeholder text: '[Click here and type name of person]', '[Click here and type title of person]', '[Click here and type name of company]', and '[Click here and type name of street address]'. The right column contains the company name 'BenQ Corporation' followed by four lines of contact information: '16 Jhu Road, Neihu', 'Taipei 114, Taiwan', 'Tel: +886-2-2658-8880', and 'Fax: +886-2-2797-9288'. At the bottom left, there is a page number placeholder: 'Page 1 of [Click here and type # of pages]'. At the bottom right, there is a website placeholder: 'BenQ.com'.

Chinese Letterhead Template



The Chinese Letterhead Template features a decorative background with a grid of dots in shades of purple and blue. In the top left corner, there is a BenQ logo. The text is arranged in two columns. The left column contains the date 'May 3, 2011' followed by four lines of placeholder text: '[Click here and type name of person]', '[Click here and type title of person]', '[Click here and type name of company]', and '[Click here and type name of street address]'. The right column contains the company name '明基電通股份有限公司' followed by four lines of contact information: '台北市 114', '內湖區基湖路 16 號', '電話: (02) 2727-8899', and '傳真: (02) 2797-9288'. At the bottom left, there is a page number placeholder: 'Page 1 of [Click here and type # of pages]'. At the bottom right, there is a website placeholder: 'BenQ.com'.



C 07.08 Electronic Items Boilerplate Template

Size

A4 297mm x 210mm

File Type

Microsoft Word .doc

English Boilerplate Template



Press Release
FOR IMMEDIATE RELEASE

For more information, please contact:
Name
BenQ Corporation
Tel. +
Fax. +
Email: name@BenQ.com

Title

Sub-Title

CITY, COUNTRY, Month Day, 2011 – BenQ announces.....

■ **About BenQ Corporation**
BenQ Corporation, a leading provider of networked digital lifestyle devices, is a multi-faceted company with strengths in product design, visual technology and mobile technology. BenQ offers unrivalled breadth and depth of products and integrated technologies across platforms through the brand promise of "Bringing Enjoyment and Quality to Life," including digital projectors, LCD monitors, LCD TVs, digital cameras, eBook readers, mobile internet devices, storage devices, and human interface devices such as mice and keyboards.

■ **About BenQ Group**
The BenQ Group is currently comprised of companies that operate independently while sharing resources and leveraging synergies among them. The BenQ Group companies include BenQ Corporation, AU Optronics Corporation (world's top 3 manufacturer of large-size TFT-LCD panels), Onda Corporation, Darfon Electronics Corporation, BenQ Materials Corp., BenQ Guru Software Co., BenQ Hospital, BrightView Corp., Cando Corporation, Daxin Materials Corp., Darwin Precisions, Ltd, Dazzo Technology Corp., Forhouse Corp., SIPix Imaging, Lextar Electronics Corp., Raydium Semiconductor Corp., Trident Medical Corp., and Wellypower Corp.

###

Chinese Boilerplate Template



新聞發佈
2011/5/3

標題
副標題

#

關於明基電腦
明基電腦成立於1984年，於2001年推出自創品牌BenQ，並於2007年9月1日與代工製造業務正式分割。BenQ以「享受快樂科技」為品牌定位，以「數位時尚網絡產品」為核心發展概念，具產品設計、視覺科技及移動科技三大核心競爭力，產品涵蓋消費性電子、資訊產品及周邊、行動通訊及3C數位匯流整合等產品，包括數位投影機、液晶顯示器、數位相機、Joybook筆記型電腦、Joybook Lite小筆電、nScreen All-in-One PC上網一體機、大型液晶、電子書閱讀器、行動通訊產品、電腦週邊產品等多元化產品線。

關於明基友建集團
明基友建集團旗下共有十餘家獨立公司，包括BenQ明基電腦、友達光電（全球前三大液晶顯示面板設計產製公司）、佳世達科技、達方電子、明基材料（原達信科技）、明基逐鹿、明基醫院、樂智電子光電、達虹科技、達興材料、達運精密、達宙通訊系統、聯祥實業、達意科技、隆達電子、瑞鼎科技、三豐醫療、威力豐電子等。集團公司掌握關鍵技術，以水平整合、垂直分工方式互享資源、相互協調。

新聞聯絡人
媒體聯絡 品牌管理部 楊正慶 (02) 2727-8899, ext. 7292 andrea.vanq@benq.com
(0963) 199-689



C 07.09 Electronic Items Factsheet

Size

A4 297mm x 210mm

File Type

Microsoft Word .doc

English Factsheet Template



Company Factsheet

Last Update: May, 2011

Company Founded	April 21, 1984 (separated from manufacturing business since Sept. 1, 2007)
Brand Launched	December 5, 2001
Paid-in Capital	USD118 Million
Chairman	K.Y. Lee
CEO	Conway Lee
Management Team	K.Y. Lee, Jerry Wang, Conway Lee, Peter Chen, Adrian Chang, Adams Lee, Lars Yoder, Peter Tan, Tony C.T. Yang
Corporate Vision	Bringing Enjoyment and Quality to Life
Product Focus	Networked Digital Lifestyle Devices
Product Lines	<ul style="list-style-type: none"> ● Digital Projector: Digital Projector (data & video) ● LCD Monitor: 15.6"W, 17", 18.5"W, 19", 19"W, 20"W, 21.5"W, 22"H, 23"W, 23.6"W, 24"W, 27"W ● Mobile Computing Product: Tablet PCs ● Digital Camera: 14 Mega pixels with high zoom lens digital cameras ● Digital Camcorder: High zoom lens digital camcorders ● LCD TV: 32", 37", 42", 46", 52" ● Mobile Communication Devices ● nReader eBook Reader ● Others <ul style="list-style-type: none"> ◇ Optical storage product: CD-ROM, CD-RW, DVD-ROM, DVD+RW, Blu-Ray RW ◇ Human interface device: mouse, keyboard ◇ Computing peripherals: digital media
Sales Offices	<p>5 Regional Operations</p> <ul style="list-style-type: none"> ● Europe (Regional HQ: Eindhoven, The Netherlands) Austria (Vienna), France (Suresnes), Germany (Oberhausen), Italy (Milan), Russia (Moscow), Spain (Barcelona), Sweden (Taby), Switzerland (Dietikon), The Netherlands (Eindhoven), UK (Weston-on-the-Green) ● North America (Regional HQ: Irvine, California, U.S.A.) Canada (Irvine), USA (Irvine) ● Latin America (Regional HQ: Miami, Florida, U.S.A.) Brazil (Sao Paulo), Mexico (Mexico City)

Chinese Factsheet Template



Company Factsheet

更新時間：2011年5月

成立日期	1984年4月21日 (2007年9月1日完成與代工業務的分劃)
品牌創立	2001年12月5日
實本額	新台幣 38.55 億元
董事長	李焜耀
執行長	李文德
經營團隊	李焜耀、王文雄、李文德、陳其宏、張安佐、Lars Yoder、楊承泰、李博弘、權力
企業願景	傳達資訊生活的真善美
產品定位	網絡時尚生活產品
產品組合	<ul style="list-style-type: none"> ● 數位投影機：短焦系列、專業級高亮度系列、主流級高解析度系列、超輕薄可攜式系列、入門級家用/商用系列、家庭劇院系列 ● 液晶顯示器：15.6"寬螢幕、17"、18.5"、19"、19"寬螢幕、20"寬螢幕、21.5"寬螢幕、22"寬螢幕、23"寬螢幕、23.6"寬螢幕、24"寬螢幕、27"寬螢幕 ● 移動上網裝置：筆記型電腦、平板電腦 ● 數位相機：10M~14M 畫素數位相機 ● 數位攝影機：高光變數位攝影機 ● 液晶電視：32"、37"、42"、46"、52" ● 電子書閱讀器：nReader ● 其他： <ul style="list-style-type: none"> ◇ 光儲存產品：光碟機、光碟燒錄機、DVD 光碟機、DVD 光碟燒錄機、藍光光碟燒錄機 Combi 複合機 ◇ 電腦週邊產品：滑鼠、鍵盤、光儲存媒體
全球業務區	<p>5 大業務區</p> <ul style="list-style-type: none"> ● 歐洲 (區域總部：Eindhoven, The Netherlands) 經銷據點：奧地利 (Vienna)、法國 (Suresnes)、德國 (Oberhausen)、義大利 (Milan)、俄羅斯 (Moscow)、西班牙 (Barcelona)、瑞典 (Taby)、瑞士 (Dietikon)、荷蘭 (Eindhoven)、英國 (Weston-on-the-Green) ● 北美洲 (區域總部：Irvine, California, U.S.A.) 經銷據點：加拿大 (Irvine)、美國 (Irvine)



C 07.10 Electronic Items Company Profile

Size

A4 297mm x 210mm

File Type

Microsoft PowerPoint .ppt

English Company Profile Template

BenQ Company Profile

Presenter's Name
Department/ Title
Company Name
Date



BenQ Innovation & R&D

- 352 patents
- 107 patents pending (2011/ 4)
- 20% of the employees are R&D talents
- 90 % engineer talents possess a PhD or a Master's Degree

Glida 4C ODM / EMS service	Raylum TF FLCED driver IC solutions	Webpower CCFL& LED
AIKO TFT LCD and fast panel technology	BenQ Materials Thin-film technology and polarizer	Darwin Backlight Modules
Cando Touch panel and color filter	Darfon FPD & Precise Components	Daxin Polymer materials
Lexar LED lighting	portopia Backlight Modules	CIPIA Electrical Paper Display
		BenView LCD TV OEM/Service

Chinese Company Profile Template

BenQ Company Profile

Presenter's Name
Department/ Title
Company Name
Date



BenQ Innovation & R&D

- 共 354 項專利
- 另 110 項專利申請中 (2011 年 4 月)
- 20% 的員工為研發人員
- 其中 90 % 擁有碩士、博士學位

信利顯示科技 ODM/EMS製造服務	精誠科技 LCO驅動晶片技術研發	威力光電子 冷陰極光管 (CCFL)
AIKO TFT LCD 面板技術	BenQ Materials 電子化學材料及偏光片技術研發	Darwin 背光模組
Cando 薄膜彩色濾光片之光電技術	Darfon 光電元件及精密電阻元件技術研發	Daxin 液晶材料
Lexar LED 顯示器 LED 背光	portopia LED 背光產品	CIPIA 電子顯示技術
		BenView 液晶電視 OEM/製造服務